

Agilent Technologies N5261A and N5262A

User's and Service Guide

Millimeter Head Controller

Use this manual with the following documents:

- PNA-X Series Network Analyzer On-line Help System
- Technical Overview 5989-7620EN
- N5256/57/58A Millimeter-Wave Modules (N5256-90001).



Agilent Technologies

Manufacturing Part Number: N5262-90001

Printed Date: November 2009

Supersede: September 9, 2009

© Copyright Agilent Technologies, Inc. 2008, 2009

Warranty Statement

THE MATERIAL CONTAINED IN THIS DOCUMENT IS PROVIDED “AS IS,” AND IS SUBJECT TO BEING CHANGED, WITHOUT NOTICE, IN FUTURE EDITIONS. FURTHER, TO THE MAXIMUM EXTENT PERMITTED BY APPLICABLE LAW, AGILENT DISCLAIMS ALL WARRANTIES, EITHER EXPRESS OR IMPLIED WITH REGARD TO THIS MANUAL AND ANY INFORMATION CONTAINED HEREIN, INCLUDING BUT NOT LIMITED TO THE IMPLIED WARRANTIES OF MERCHANTABILITY AND FITNESS FOR A PARTICULAR PURPOSE. AGILENT SHALL NOT BE LIABLE FOR ERRORS OR FOR INCIDENTAL OR CONSEQUENTIAL DAMAGES IN CONNECTION WITH THE FURNISHING, USE, OR PERFORMANCE OF THIS DOCUMENT OR ANY INFORMATION CONTAINED HEREIN. SHOULD AGILENT AND THE USER HAVE A SEPARATE WRITTEN AGREEMENT WITH WARRANTY TERMS COVERING THE MATERIAL IN THIS DOCUMENT THAT CONFLICT WITH THESE TERMS, THE WARRANTY TERMS IN THE SEPARATE AGREEMENT WILL CONTROL.

DFARS/Restricted Rights Notice

If software is for use in the performance of a U.S. Government prime contract or subcontract, Software is delivered and licensed as “Commercial computer software” as defined in DFAR 252.227-7014 (June 1995), or as a “commercial item” as defined in FAR 2.101(a) or as “Restricted computer software” as defined in FAR 52.227-19 (June 1987) or any equivalent agency regulation or contract clause. Use, duplication or disclosure of Software is subject to Agilent Technologies’ standard commercial license terms, and non-DOD Departments and Agencies of the U.S. Government will receive no greater than Restricted Rights as defined in FAR 52.227-19(c)(1-2) (June 1987). U.S. Government users will receive no greater than Limited Rights as defined in FAR 52.227-14 (June 1987) or DFAR 252.227-7015 (b)(2) (November 1995), as applicable in any technical data.

Safety and Regulatory Information

The safety and regulatory information pertaining to this product is located in [“Safety and Regulatory Information”](#) on page 79.

Definitions

- *Specifications* describe the performance of parameters covered by the product warranty (temperature –0 to 55 °C, unless otherwise noted.)
- *Typical* describes additional product performance information that is not covered by the product warranty. It is performance beyond specification that 80% of the units exhibit with a 95% confidence level over the temperature range 20 to 30 °C. Typical performance does not include measurement uncertainty.
- *Nominal* values indicate expected performance or describe product performance that is useful in the application of the product, but is not covered by the product warranty.
- *Characteristic Performance* describes performance parameter that the product is expected to meet before it leaves the factory, but is not verified in the field and is not covered by the product warranty. A characteristic includes the same guard bands as a specification.

Contents

N5261A and N5262A

Introduction	2
Typical System Configurations	2
Description	4
Network Analyzer Requirements	4
Available Options	5
Accessory Options	5
Cable Options	5
Verifying Your Shipment	6
Contents List	7
Compatible Millimeter-wave Modules	10
Caring for Waveguide Standards and Flanges	13
Specifications	14
Environmental Requirements	15
Environmental Tests	15
Heating and Cooling in the Operating Environment	15
Required Conditions for Accuracy Enhanced Measurement	15
Component Weight and Dimensions	16
Front Panel Features	17
Rear Panel Features	19
Available Fuses	20
System Configuration and Operation	21
Site Preparation	21
Protect Against Electrostatic Discharge (ESD)	21
Power Requirements	21
System Setup with N5242A, N5244A or N5245A	22
Preparing the N5242/44/45A Network Analyzer	22
Front Panel Cabling	26
Millimeter-wave Module Connections	28
Rear Panel Cabling	29
Controlling the N5261/62A with the PNA-X	31
PNA-X Millimeter Mode	31
Calibrating the System	35
Operational Check	38
Non-System Operation Check	38
Required Equipment	38
Verifying the N5261/62A (Millimeter Head Controller)	38
System Operation Check	44
Required Equipment	44
Information Required for the Operator's Check	45
Preparing the PNA-X	45
Initial System Verification	46
Verifying a Waveguide Section with a 2-Port Calibration	50
Verifying a Waveguide Short with a 1-Port Calibration	56
Theory of Operation	61
Functional Block and Assembly Information	61
Test Set Controller Board (N5261-60006)	61
Interface Board (N5261-60001)	61
LED Board (N5261-60005)	61
DC Power Board (N5261-60002)	61
Power Supply (0950-4729)	62
Isolators (0955-1595)	62

Contents

LO Power Amplifier (5087-7290)62
RF and LO ALC Amplifier (5086-7523)62
Attenuator, 6 dB (0955-0243)62
Attenuator, 3 dB (0955-0246)62
Coupler (0955-0148)62
IF Gain Board (N5261-60008)62
Power Divider (N5262-80003)63
RF Switch (5087-7238)63
Troubleshooting67
Fan is not Operating67
No DC Power for Millimeter-wave Modules68
Over Current LEDs (amber) are On68
Front Panel LEDs R, S or DC Power (green) are not Illuminated69
Test Ports are not Switching (RF OUT)70
No LO Output70
Safety and Regulatory Information79
Introduction79
Before Applying Power79
Connector Care and Cleaning79
Declaration of Conformity79
Statement of Compliance79
General Safety Considerations80
Cautions applicable to this instrument80
Servicing81
Regulatory Information82
Instrument Markings82
Battery Collection83
Compliance with German Noise Requirements83
EMC Information83
Electrostatic Discharge Protection84
Agilent Support, Services, and Assistance85
Service and Support Options85
Contacting Agilent85
Shipping Your Analyzer to Agilent for Service or Repair85

N5261A and N5262A

Introduction

This document describes the N5261A and N5262A Millimeter Head Controller features and options, as well as connections to the N5242A, N5244A and N5245A PNA-X and millimeter-wave modules. For further Banded Millimeter-wave information, refer to Technical Overview 5989-7620EN.

Typical System Configurations

Figure 1 2-Port Millimeter Wave Configuration (N5261A)

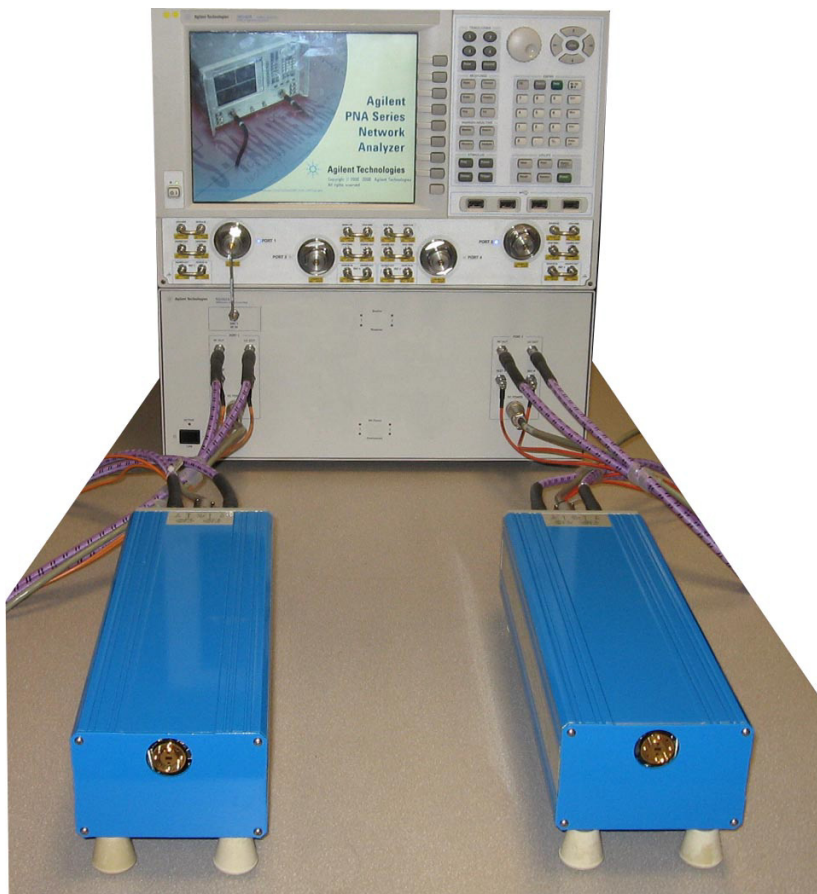
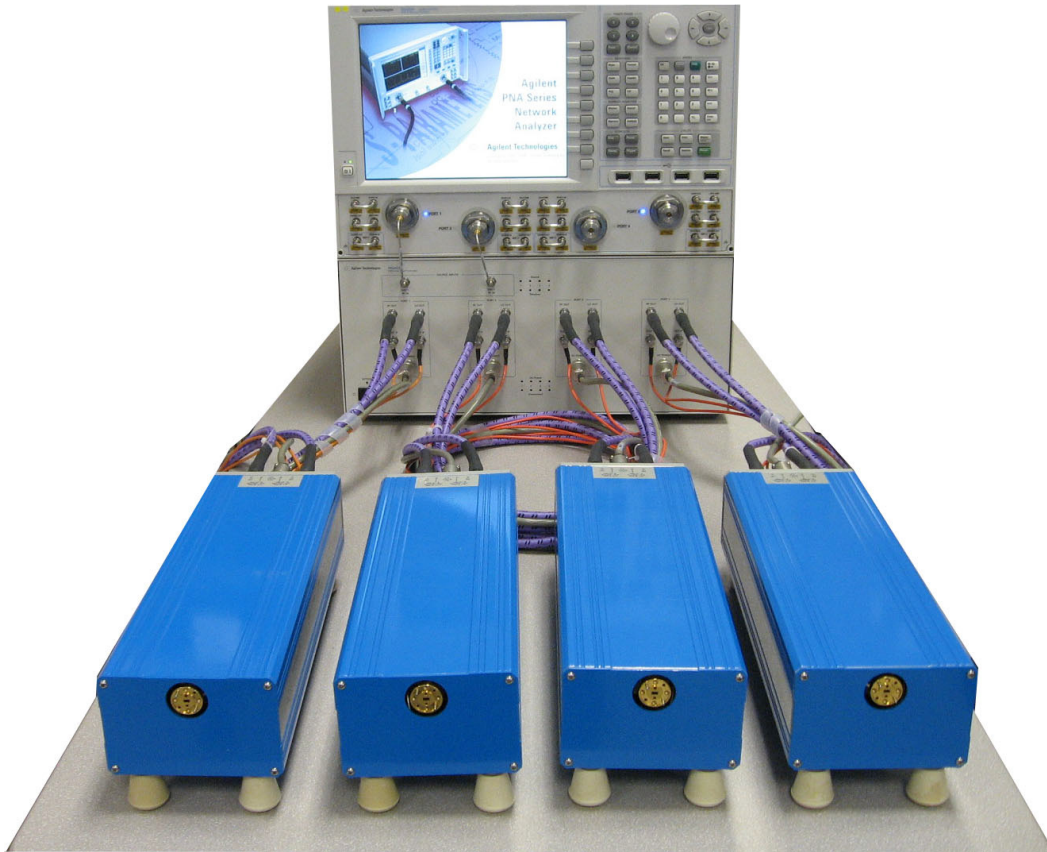

Figure 2 4-Port Millimeter Wave Configuration (N5262A)



Description

The N5261/62A Millimeter Head Controller, referred to as the test set, provides the interface between the millimeter-wave modules and a N5242A, N5244A or N5245A, referred to as the PNA-X series network analyzer.

The millimeter head controller, when used in conjunction with the millimeter-wave modules and the PNA-X, provides all of the features and functions of a millimeter-wave vector network analyzer with the frequency range of the millimeter-wave modules used.

The millimeter head controller amplifies and routes the RF and LO signals to the millimeter-wave modules, and returns the down converted reference and test IF signals to the PNA-X for processing and display. The N5261/62A Millimeter Head Controller also supplies the +12 Vdc power to each millimeter-wave module. Refer to the [Figure 52](#) through [Figure 55](#) beginning on [Page 64](#).

A typical system configuration is illustrated in [Figure 1](#) and [Figure 2](#) on [page 3](#).

Network Analyzer Requirements

The N5242A PNA-X requires the following option combinations for proper operation with the N5261/62A Millimeter Head Controller.

- PNA-X firmware revision:
N5242A \geq A.08.20.04
N5244/45A \geq A.08.60.07
- The N5261A with an N5242A or N5244/45A Option 200 or 400 requires Option 020.
- The N5262A with an N5242A or N5244/45A Option 200 requires Option 020 and 550 or 551 for 4-Port system.
- The N5262A with an N5242A or N5244/45A Option 400 requires Option 020.
- The N5261A with an N5242A or N5244/45A Option 219 or 224 requires Option 020.
- The N5262A with an N5242A or N5244/45A Option 219 or 224 requires Option 020 and 550 or 551 for 4-Port system.
- The N5262A with an N5242A or N5244/45A Option 419 or 423 requires Option 020.

Available Options

Accessory Options

Installation instructions are included in the option package.

- Option 1CM - Rackmount Kit (5063-9215).
- Option 1CN - Front Handle Kit (5063-9228).
- Option 1CP - Rackmount with front handle Kit (5063-9222).

Cable Options

An external amplifier is required for higher frequency millimeter-wave modules with some cable options. Refer to [Table 2, “Cable and Millimeter Module Combinations,” on page 11.](#)

- Option 501 - 1-Port Millimeter Module Cable Set (48 in, 1.22 m)
- Option 502 - 1-Port Millimeter Module Cable Set (79 in, 2 m)
- Option 503 - 1-Port Millimeter Module Cable Set (118 in, 3 m)
- Option 505 - 1-Port Millimeter Module Cable Set (197 in, 5 m)
- Option 102 - Cable Set 2-Port N5242A to Test Set
- Option 104 - Cable Set 4-Port N5242A to Test Set
- Option 106 - 2.4 mm Cable Set for 2-Port N5244/45A to the Test Set
- Option 108 - 2.4 mm Cable Set for 4-Port N5244/45A to the Test Set

Verifying Your Shipment

Each N5261/62A Millimeter Head Controller product includes:

- The N5261/62A Millimeter Head Controller.
- Option specific interconnection cables and adapters. Refer [Table 1 on page 7](#). The PNA-X and Millimeter-wave modules must be ordered separately.
- The N5261/62A Millimeter Head Controller User's Guide (the document you are now reading). This document provides system connection and basic operation information, using an N5261/62A Millimeter Head Controller with banded millimeter-wave modules.

WARNING **The N5261/62A Millimeter Head Controller and the millimeter-wave modules are sensitive to electrostatic discharge (ESD). Ground your work station before unpacking and installing the millimeter-wave modules. See [“Electrostatic Discharge Protection” on page 84](#).**

For a list of components shipped with your N5261/62A, refer to [Table 1, “N5261/62A Option Content List,” on page 7](#).

Keep the shipping containers until the N5261/62A component checklist has been completed, and the components have been checked for physical damage.

If the shipping container is damaged or the packaging material shows signs of stress, notify the carrier as well as the Agilent Technologies Field Engineer. Keep the shipping materials for the carrier's inspection. Agilent Technologies will arrange for repair or replacement of damaged equipment without waiting for a claim settlement from the carrier. Refer to [“Contacting Agilent” on page 85](#).

Contents List

Use the table below to verify the your specific option shipment is complete.

Table 1 N5261/62A Option Content List

✓	Agilent Part Number	Qty	Description
	N5261A or N5262A	1	Millimeter Head Controller
	5023-0132	1	Locking Feet Kit
	0515-2317	2	Screw
	8120-6818	1	Test Set Interface Cable (W7)
	1810-0118	1	50 Ohm Load Termination (N5261A)
	1810-0118	2	50 Ohm Load Termination (N5262A)
	9230-0333	1	Envelope (Calibration Certificate)
	9320-6636	1	Functional Certificate
	N5262-90001	1	Installation and Service Guide
	Option 1CM (Rackmount Kit)		
	5063-9251	1	Rackmount Kit
	Option 1CN (Rackmount Kit)		
	5063-9228	1	Front Handle Kit
	Option 1CP (Rackmount Kit)		
	5063-9222	1	Rackmount Kit with Front Handle Kit
	N5261A Option 102 (Cable Set 2-Port PNA-X to Test Set)		
	5061-9038	6	Rear Panel Cable Assembly (W6, W8)
	N5262-20016	1	RF Cable, SRC1 to 2-Port PNA-X (W3)
	N5242-20138	1	Right Foot
	N5242-20139	1	Left Foot
	N5261A Option 104 (Cable Set 4-Port PNA-XPNA-X to Test Set)		
	5061-9038	6	Rear Panel Cable Assembly (W6, W8)
	N5262-20018	1	RF Cable, SRC1 to 4-Port PNA-X (W1)
	N5242-20138	1	Right Foot
	N5242-20139	1	Left Foot

Table 1 N5261/62A Option Content List (Continued)

N5261A Option 106 (2.4 mm Cable Set 2-Port PNA-X to Test Set)			
5061-9038	6	Rear Panel Cable Assembly (W6, W8)	
N5262-20023	1	RF Cable - SRC1 to 2 Port PNA (W1)	
N5245-20130	1	Right Foot	
N5245-20131	1	Left Foot	
N5261A Option 108 (2.4 mm Cable Set 4-Port PNA-X to Test Set)			
5061-9038	6	Rear Panel Cable Assembly (W6, W8)	
N5262-20026	1	RF Cable - SRC1 to 4 Port PNA (W1)	
N5245-20130	1	Right Foot	
N5245-20131	1	Left Foot	
N5262A Option 102 (Cable Set 2-Port PNA-X to Test Set)			
5061-9038	7	Rear Panel Cable Assembly (W5,W6 and W8)	
N5262-20016	1	RF Cable, SRC1 to 2-Port PNA-X (W3)	
N5262-20017	1	RF Cable, SRC2 to 2-Port PNA-X (W4)	
N5262-20020	1	RF Cable, SRC2 to 2-Port PNA-X (W9)	
N5242-20138	1	Right Foot	
N5242-20139	1	Left Foot	
N5262A Option 104 (Cable Set 4-Port PNA-X to Test Set)			
5061-9038	8	Rear Panel Cable Assembly (W5,W6 and W8)	
N5262-20018	1	RF Cable, SRC1 to 4-Port PNA-X (W1)	
N5262-20019	1	RF Cable, SRC2 to 4-Port PNA-X (W2)	
N5242-20138	1	Right Foot	
N5242-20139	1	Left Foot	
N5262A Option 106 (2.4 mm Cable Set 2-Port PNA-X to Test Set)			
5061-9038	7	Rear Panel Cable Assembly (W5,W6 and W8)	
N5262-20023	1	RF Cable - SRC1 to 2 Port PNA (W3)	
N5262-20024	1	RF Cable - SRC2 to 2 Port PNA (W4)	
N5262-20025	1	RF Cable - SRC2 to Std. 2 Port PNA (W9)	
N5245-20130	1	Right Foot	
N5245-20131	1	Left Foot	

Table 1 N5261/62A Option Content List (Continued)

N5262A Option 108 (2.4 mm Cable Set 4-Port PNA-X to Test Set)			
5061-9038	8	Rear Panel Cable Assembly (W5,W6 and W8)	
N5262-20026	1	RF Cable - SRC1 to 4 Port PNA (W1)	
N5262-20027	1	RF Cable - SRC2 to 4 Port PNA (W2)	
N5245-20130	1	Right Foot	
N5245-20131	1	Left Foot	
Option 501 (1-Port Millimeter Module Cable Set (48 inches = 1.2 meter)			
8121-1221	2	RF 3.5 mm cable (RF Input and LO Input)	
85105-60030	1	Cable Assembly, DC Power (Bias)	
85105-60033	2	IF Cable Assembly (REF IF and TEST IF)	
N5260-60043	1	Wire Marker Kit	
Option 502 (1-Port Millimeter Module Cable Set (79 inches = 2 meter)			
N5260-60023	2	RF 3.5 mm cable (RF Input and LO Input)	
N5260-60024	2	IF Cable Assembly (REF IF and TEST IF)	
N5260-60025	1	Cable Assembly, DC Power (Bias)	
N5260-60043	1	Wire Marker Kit	
Option 503 (1-Port Millimeter Module Cable Set (118 inches = 3 meter)			
N5260-60026	2	RF 3.5 mm cable (RF Input and LO Input)	
N5260-60027	2	IF Cable Assembly (REF IF and TEST IF)	
N5260-60028	1	Cable Assembly, DC Power (Bias)	
N5260-60043	1	Wire Marker Kit	
Option 505 (1-Port Millimeter Module Cable Set (197 inches = 5 meter)			
N5260-60029	2	RF 3.5 mm cable (RF Input and LO Input)	
N5260-60030	2	IF Cable Assembly (REF IF and TEST IF)	
N5260-60031	1	Cable Assembly, DC Power (Bias)	
N5260-60043	1	Wire Marker Kit	

Compatible Millimeter-wave Modules

The N5256/57/58A millimeter-wave modules are designed for use with the N5260/61/62A millimeter-wave module controllers for banded vector network analyzer systems. The compatible OML manufacture modules have VNA2 in the model number.

The N5256A “T/R” millimeter-wave module contains an RF source multiplier, dual directional coupler, reference downconverter and a test downconverter. The T/R millimeter-wave module is usually the primary module of a millimeter-wave VNA system. A single T/R module allows the measurement of S11 reflection coefficient only.

The N5257A “T” millimeter-wave module is a “receive only” module that contains a test downconverter to receive the test signal from a T/R millimeter-wave module. The use of a T module, as the second module, allows the system capability to measure S11 and S21 only.

The N5258A “T2” series is a “dual receive only” module that contains two test downconverters to receive test signals from two antennas, a power splitter or two T/R millimeter-wave modules.

The use of two T/R modules in the millimeter-wave VNA system allows for all four S-parameters to be measured. The test downconverters of T/R modules are the receivers for the signal from the modules sources. When the two modules waveguide are connected, S11 and S21 are measured on the forward direction, S22 and S11 are measured when the signal path is reversed.

NOTE S12 requires a T/R module on Port 2, and a T or T/R on Port 1.
 S21 requires a T/R module on Port 1, and a T or T/R module on Port 2.
 S34 requires a T/R module on Port 4, and a T/R module or T module on Port 3.
 S43 requires a T/R module on Port 3, and a T/R module or T module on Port 4.

The Millimeter-Wave Modules can be ordered from Agilent with frequency ranges up to 500 GHz, higher frequency modules will be added as they become available. For further Banded Millimeter-Wave information, refer to the N5256/57/58A Millimeter-wave Modules (N5256-90001) and the Technical Overview (5989-7620EN) document.

[Figure 1](#) and [Figure 2](#) are typical configurations, shown with the N5256AW15-STD Millimeter-wave modules.

You may also refer to Banded Millimeter-wave Solutions up to 500 GHz, available on the Web at: <http://www.home.agilent.com>. Search banded millimeter.

CAUTION Turn *off* the N5261/62A power when connecting or disconnecting the millimeter-wave modules to prevent damage.

The test set can drive the following cable/head combinations. An external amplifier is required for higher frequency millimeter wave modules, or when using longer RF cable lengths. Longer RF cables are available up to 10 meters (N5260AK08). A separate DC supply is recommended if modules are greater than 5 meters from the controller. A DC bias power cable, with banana plug connectors, is available for use with a separate power supply such as E3615A.

Table 2 Cable and Millimeter Module Combinations

Cable Option	Cable Length	RF OUT (compatible heads)	LO OUT (compatible heads)
501	4 ft. (1.22 m)	50 to 500 GHz	50 to 500 GHz
502	6.58 ft. (2 m)	50 to 500 GHz	50 to 500 GHz
503	9.83 ft. (3 m)	50 to 500 GHz	50 to 325 GHz
505	16.4 ft. (5 m)	50 to 110 GHz	Amplifier required

To determine the required amplification for RF OUT or LO OUT, refer to [Table 3 on page 12](#) and [Figure 3](#).

Figure 3 RF Cable Loss (dB loss per foot)

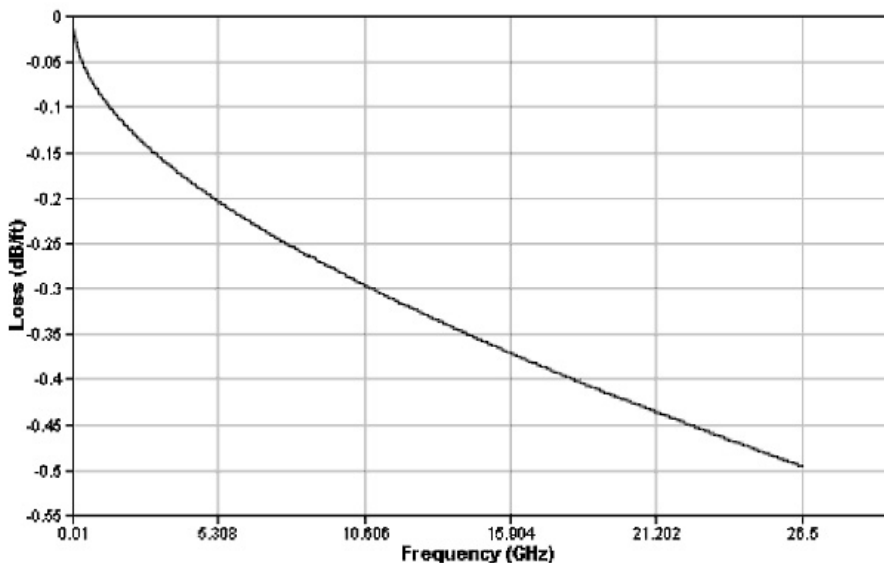

Table 3 LO and RF Power Requirements

Model	Millimeter-wave Modules	RF INPUT	LO INPUT
N5256AW22 N5257AR22 N5258AD22	WR-22 33 to 50 GHz	11 to 11.7 GHz +8 dBm (min)	8.2 to 12.5 GHz +8 dBm (min)
N5256AW15 N5257AR15 N5258AD15	WR-15 50 to 75 GHz	12.5 to 18.8 GHz +5 dBm (min)	10 to 15 GHz +5 dBm (min)
N5256AW12 N5257AR12 N5258AD12	WR-12 60 to 90 GHz	10 to 15 GHz +5 dBm (min)	12 to 18 GHz +5 dBm (min)
N5256AW10 N5257AR10 N5258AD10	WR-10 75 to 110 GHz	12.5 to 18.4 GHz +5 dBm (min)	9.3 to 13.8 GHz +5 dBm (min)
N5256AW08 N5257AR08 N5258AD08	WR-08 90 to 140 GHz	7.5 to 11.2 GHz +7 dBm (min)	11.2 to 17.5 GHz +7 dBm (min)
N5256AW06 N5257AR06 N5258AD06	WR-06 110 to 170 GHz	9.1 to 14.2 GHz +7 dBm (min)	11 to 17 GHz +7 dBm (min)
N5256AW05 N5257AR05 N5258AD05	WR-05 140 to 220 GHz	11.6 to 18.4 GHz +7 dBm (min)	11.6 to 18.4 GHz +7 dBm (min)
N5256AW03 N5257AR03 N5258AD03	WR-03 220 to 325 GHz	12.2 to 18.1 GHz +7 dBm (min)	12.2 to 18.1 GHz +7 dBm (min)
N5256AW02 N5257AR02 N5258AD02	WR-02.2 325 to 500 GHz	10.8 to 16.7 GHz +10 dBm (min) ¹	11.6 to 17.9 GHz +10 dBm (min)

1. May require amplification.

If you are installing an amplifier in the LO or RF path, ensure the amplifier's input is connected to the test set, and the output is connected to the millimeter-wave modules. Modules with built in amplifiers are available, and recommended if you are using long RF cables.

Caring for Waveguide Standards and Flanges

Waveguide calibration standards and flanges should be kept clean and scratch free.

A clean surface at millimeter-wave frequencies is much more important than at lower frequencies because any debris on the waveguide surface can potentially distort the measurement results.

WARNING Use isopropyl alcohol only in a well-ventilated area. Allow all residual alcohol moisture to evaporate, and the fumes to dissipate, prior to assembling waveguide interfaces.

To remove dirt on the waveguide surface, place a few drops of isopropyl alcohol on a lint-free cloth and gently wipe the surface. To remove dust, spray the pressurized air on the waveguide surface. It is important the aperture is clear of any debris.

- Isopropyl alcohol 99.5% (Agilent p/n 8500-5344)
- Lint-free cloth or tissue (Agilent p/n 9300-0001)
- Pressurized air, for dust removal. (Agilent p/n 8500-6251)

CAUTION Ensure the standards are not damaged when you are making the connections. When connecting the standards, avoid scratching the surface of the shims. It is best to position the Null or Offset $\frac{1}{4}$ Shim onto the guide posts of the waveguide flange first, and then insert the guide pins. If you are using the guide pins, insert them into the Short or Load first, and then carefully install it onto the waveguide flange. Guide pins are not required when using a short.

Specifications

Specifications for the N5261A or N5262A Millimeter Head Controller are intended as information to confirm operation and use of the Millimeter Head Controller in a system.

The connectors listed in [Table 4](#) must be torqued to 57 N-cm (5 in-lb).

Table 4 N5261/62A Characteristics

Front/Rear Panel Connector ¹	Power	Frequency Range
RF OUT Minimum ²	+8 dBm	7.5 to 19 GHz
RF OUT Maximum ²	+13 dBm	
LO OUT Minimum ²	+10 dBm	8 to 19 GHz
LO OUT Maximum ²	+13 dBm	
TEST IF Typical	-27 dBm	1 to 20 MHz
TEST IF Maximum ³	-10 dBm	
REF IF Typical	-27 dBm	1 to 20 MHz
REF IF Maximum ³	-10 dBm	
LO IN	+2 to -10 dBm	8 to 19 GHz
TEST IF to A-D IF OUT ⁴	0 dB (± 2 dB)	1 to 20 MHz
REF IF to A-D IF OUT ⁵	0 dB (± 2 dB)	1 to 20 MHz
REF IF to R IF OUT ⁴	0 dB (± 2 dB)	1 to 20 MHz
SRC 1 RF IN Minimum ⁶	0 dBm	7.5 to 19 GHz
SRC 1 RF IN Maximum	+15 dBm	
SRC 2 RF IN Minimum ⁶	0 dBm	7.5 to 19 GHz
SRC 2 RF IN Maximum	+15 dBm	

1. All connectors are SMA.
2. Gain is 12 to 35 dB, ALC range > 40 dB.
3. -10 dBm is full scale to PNA-X IF Input.
4. Relative to the TEST IF power level.
5. Relative to the REF IF power level.
6. -10 dBm RF Input is the minimum for +8 dBm RF Output.

Environmental Requirements

Refer to the N5242A, N5244A or N5245A User's Guides for environmental specifications.

NOTE Samples of this product have been type-tested in accordance with the Agilent Environmental Test Manual and verified to be robust against the environmental stresses of storage, transportation and end-use; those stresses include but are not limited to temperature, humidity, shock, vibration, altitude and power-line conditions. Test methods are aligned with IEC 60068-2 and levels are similar to MIL-PRF-28800F Class 3.

Environmental Tests

The N5261/62A complies with all applicable safety and regulatory requirements for the intended location of use and have been evaluated to assure that they are consistent with Agilent quality and reliability goals.

Heating and Cooling in the Operating Environment

Install air conditioning and heating, if necessary, to maintain the ambient temperature within the appropriate range specified for your instrument.

Required Conditions for Accuracy Enhanced Measurement

Accuracy-enhanced (error-corrected) measurements require the ambient temperature of the N5261/62A to be maintained within ± 1 °C of the ambient temperature at calibration.

CAUTION This product is designed for use in Installation Category II and Pollution Degree 2.

Component Weight and Dimensions

Table 5 and Table 6 illustrate the maximum weight and dimensions of the system components.

WARNING **The network analyzer is heavy. It is recommended that two individuals, or a mechanical lift be used to lift or transport the instrument.**

Table 5 Dimensions

Model	Weight	Height	Width	Depth
Millimeter-wave Module (each)	3.5 kg (7.5 lb, ± 0.5 lb)	6.9 cm (2.7 in)	33.0 cm (12.9 in)	17.8 cm (6.9 in)
N5261A Millimeter Head Controller	10 kg (22 lb)	18 cm (7.1 in)	42.5 cm (16.75 in)	42.5 cm (16.75 in)
N5262A Millimeter Head Controller	11 kg (24.2 lb)	18 cm (7.1 in)	42.5 cm (16.75 in)	42.5 cm (16.75 in)
N5242A PNA-X	See Table 6.	26.7 cm (10.5 in)	42.5 cm (16.8 in)	55.8 cm (21.97 in)
N5244A or N5245A PNA-X	See Table 6.	26.7 cm (10.5 in)	42.5 cm (16.8 in)	58.2 cm (22.9 in)

Table 6 Weights

Weight		
Model	2-Port Modules (Option 200, or 219 or 224)	4-Port Modules (Option 400, or 419 or 423)
N5242A PNA-X	27 Kg (60 lb) nominal	37 Kg (82 lb) nominal
N5244A or N5245A PNA-X	39.1 Kg (86 lb) nominal	41.8 Kg (92 lb) nominal

Front Panel Features

Figure 4 N5261A (2-Port) Front Panel Features

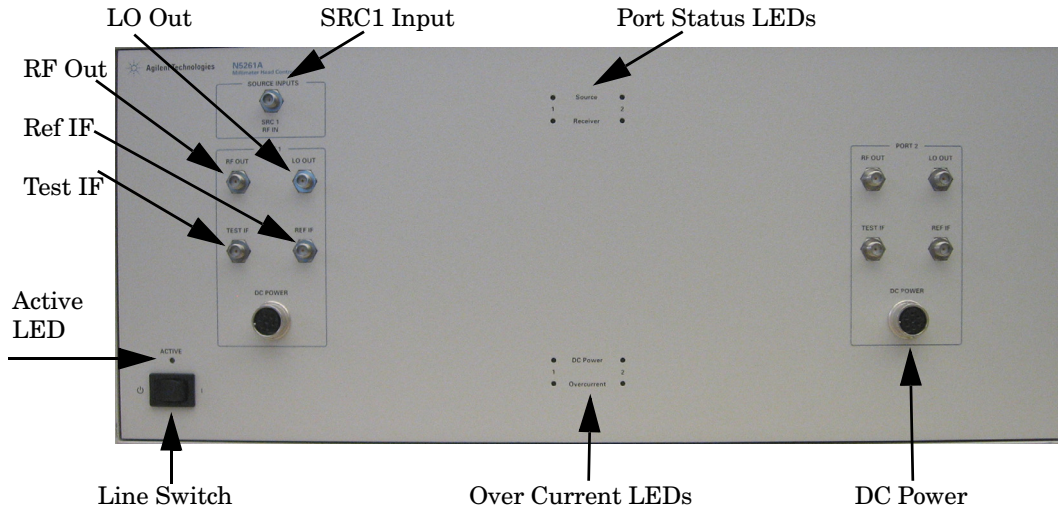
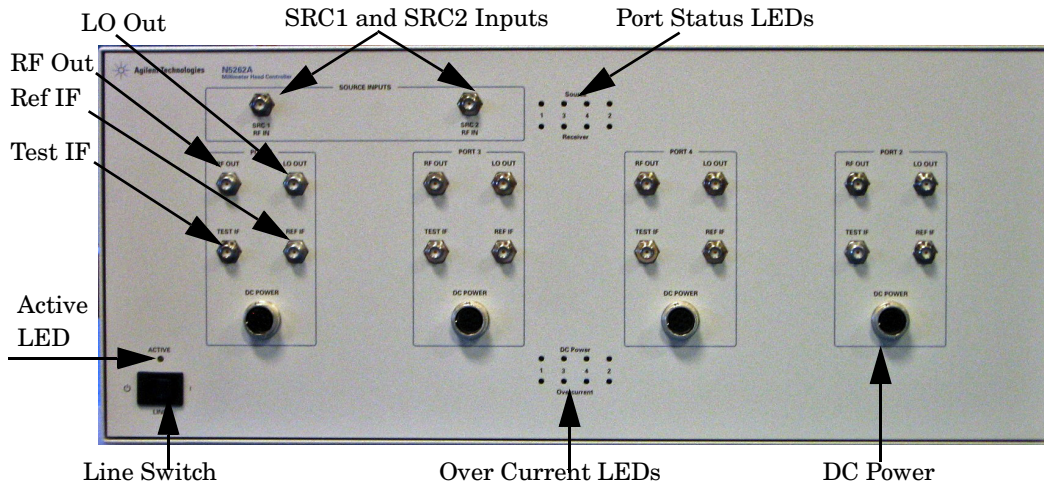



Figure 5 N5262A (4-Port) Front Panel Features



Line Switch. This switch turns the test set on and off.

-  – Standby
- | – ON (Active LED On)

Active LED.

- The LED is *on* when the test set power switch is on and addressed by a PNA-X.
- The LED is *off* when the test set power switch is in Standby, or not addressed by a PNA-X.

Port Status LEDs. The amber LEDs indicate which source port is active. The green LEDs indicate which receiver port is active.

DC Power/Over Current LEDs. The green LEDs indicate that the DC power bias is on. The amber LEDs indicate an over current condition.

RF OUT. Provides an amplified RF source signal to the millimeter-wave module.

LO OUT. Provides amplified LO signal to the millimeter-wave module.

TEST IF. IF signal input connection from the millimeter module.

REF IF. Reference IF signal input connection from the millimeter module.

DC Power (Bias). This bias supplies the +12.5 volts DC and ground lines to the millimeter-wave modules. Pins 1 and 3 are both +12.5 Vdc supplies. Pins 4 and 6 are the dc supply ground lines. Pins 2, 5, and 7 are unused.

SRC1. Connects to the front panel PNA-X test ports.

SRC2. Connects to the front panel PNA-X test ports.

NOTE The SRC2 Input and Ports 3 and 4 features are not present on the N5261A. Refer to [Figure 1 on page 2](#).

Rear Panel Features

Figure 6 N5261/2A Rear Panel Features

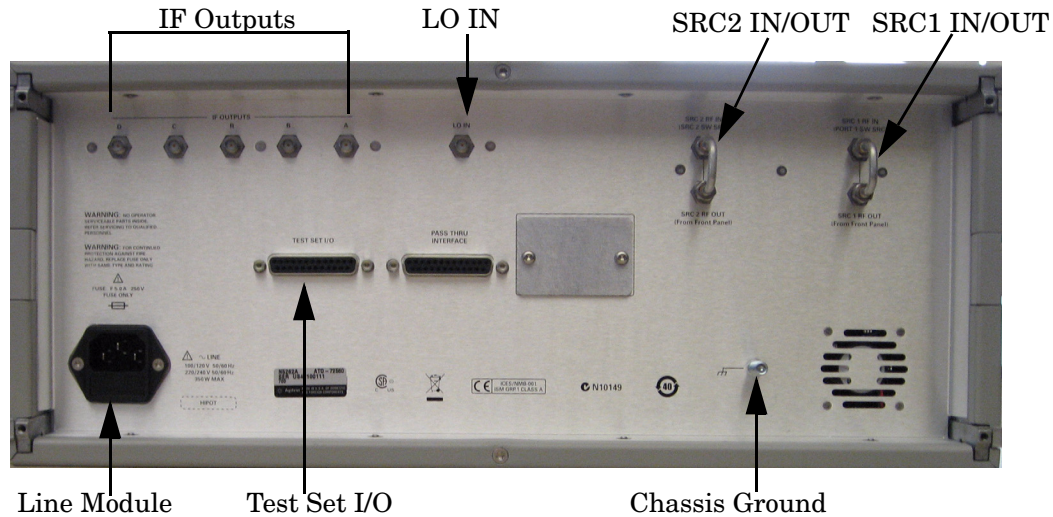

Chassis Ground. The connection or bonding of an equipment chassis to a conductive object or structure to ensure a common potential.

LO IN. This input is from the LO drive of the PNA-X. The signal is split and amplified then output to the front panel of the N5261/62A.

D IF Output. IF signal from the test set to the PNA-X IF D Input.

C IF Output. IF signal from the test set to the PNA-X IF C Input.

R IF Output. REF IF from the test set to the PNA-X IF R Input. (N5261A, not installed)

A IF Output. IF signal from the test set to the PNA-X IF A Input.

B IF Output. IF signal from the test set to the PNA-X IF B Input.

Test Set Interface I/O. The Test Set Interface connector is used to send address and data to the test set from the PNA-X.

Pass Through Interface. Connection to another test set.

SRC 1 RF IN and SRC 1 RF OUT. Jumper installed (E8356-20072).

SRC 2 RF IN and SRC 2 RF OUT. N5261A, jumper and connectors are not installed.

Line Module. This assembly houses the line cord connection, line fuse, and line voltage selector. Remove the line module cover to replace or change the fuse. Line voltage selection is automatic and no setting is required. Recommended fuse values are printed on the rear panel of the N5261/62A.

Available Fuses

- Fuse (F 5 A/250V, 2110-0709) UL listed and CSA certified.

WARNING For continued protection against fire hazard replace line fuse only with same type and rating: Fuse 5A/250V, Part Number 2110-0709
The use of other fuses or material is prohibited.

Figure 7 Line Fuse



CAUTION This instrument has autoranging line voltage input; be sure the supply voltage is within the specified range.

System Configuration and Operation

Site Preparation

Protect Against Electrostatic Discharge (ESD)

This is important. If not properly protected against, electrostatic discharge can seriously damage your analyzer, resulting in costly repair.

CAUTION To reduce the chance of electrostatic discharge, follow all of the recommendations outlined in [“Electrostatic Discharge Protection” on page 84.](#)

WARNING No operator serviceable parts inside. Refer servicing to qualified personnel. To prevent electrical shock do not remove covers.

Power Requirements

Before installing the PNA-X and N5261/62A, be sure that the required AC power is available at all necessary locations.

- 100/120/220/240 V (50/60 Hz)
- Three-wire power cables (which provide a safety ground) must be used with all instruments.
- Air-conditioning equipment (or other motor-operated equipment) should not be placed on the same ac line that powers the system.
- The table below lists the maximum VA ratings and BTU/hour ratings for all instruments in the configuration. This table can be used to determine both the electrical requirements and the air conditioning requirements of the system.

Table 8 Power Requirements of a Standard Configuration

Standard Equipment	
Instrument	Maximum Watt
N5242A	270
N5244A or N5245A	450
N5261/62A Millimeter Head Controller	350
Millimeter-wave modules	(powered from controller)

System Setup with N5242A, N5244A or N5245A

Install the instrument so that the detachable power cord is readily identifiable and is easily reached by the operator. The detachable power cord is the instrument disconnecting device. It disconnects the mains circuits from the mains supply before other parts of the instrument. The front panel switch is only a standby switch and is not a LINE switch. Alternatively, an externally installed switch or circuit breaker (which is readily identifiable and is easily reached by the operator) may be used as a disconnecting device.

WARNING This is a Safety Class 1 Product (provided with a protective earthing ground incorporated in the power cord). The mains plug shall only be inserted in a socket outlet provided with a protective earth contact. Any interruption of the protective conductor inside or outside of the product is likely to make the product dangerous. Intentional interruption is prohibited.

WARNING The network analyzer is heavy. It is recommended that two individuals, or a mechanical lift be used to lift or transport the instrument.

Preparing the N5242/44/45A Network Analyzer

The main power cord can be used as the system disconnecting device. It disconnects the mains circuits from the mains supply.

1. Remove the feet from the bottom of the network analyzer. Refer to [Figure 7](#).
2. Remove the 2 lower standoffs and screws (0515-1619) from the rear panel on the network analyzer.

Figure 7 Rear Bottom Feet

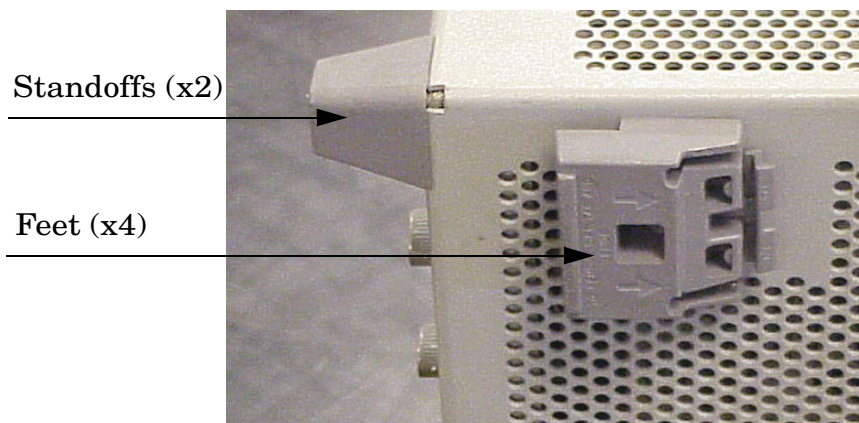

3. Install the two rear locking feet (5023-0132) onto the PNA-X, using the included screws (0515-1619), where the standoffs were removed.

Figure 8 Install Locking Feet on N5242/44/45A

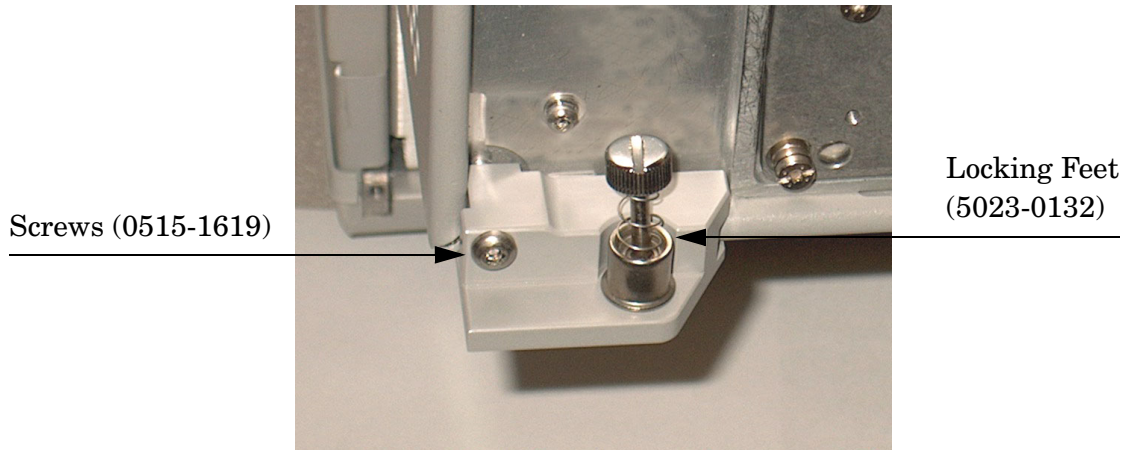

4. Install the two rear locking feet onto the N5261/62A, using two screws (0515-2317) included in shipment. Looking at the front panel, the N5242-20138 is the right foot and the N5242-20139 is the left foot for use with the N5242A. The N5245-20130 is the right foot and the N5245-20131 is the left foot for use with the N5244A or N5245A.

Figure 9 Install Locking Feet on N5261/62A



5. Place the network analyzer on top of the Test Set and ensure that the front frame of the network analyzer is positioned slightly forward of the locks that are attached to the Test Set. Slide the network analyzer back so the locks engage the front frame of the analyzer.

Figure 10 Locking the Analyzer's

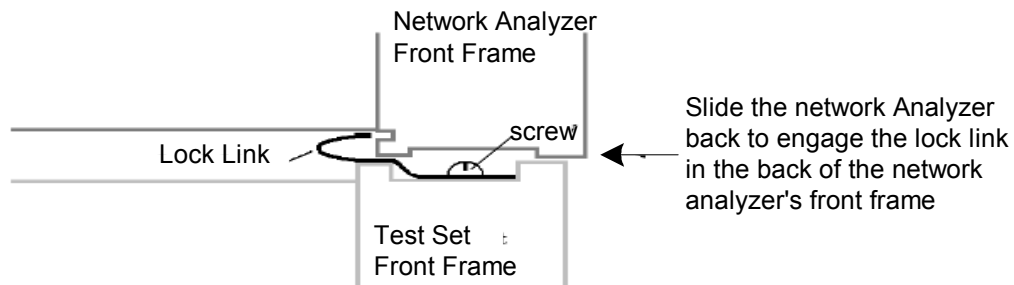

6. Secure the network analyzer's lower locking feet to the Test Set upper locking feet, using the spring-loaded screws on the locking feet. Refer to [Figure 11](#). If the network analyzer's lower locking feet are not aligned with the screw holes in the Test Set's upper locking feet, loosen the screws securing the feet to the instrument slightly to align.

Figure 11 Locking Feet Screws



NOTE

There are two Lock-Foot kits available. Refer to [“Contacting Agilent” on page 85](#) for ordering information.

- PNA-X – 5023-0132 (Kit includes locking feet and screws)
- Test Set – N5242-20138 is the right foot and N5242-20139 is the left foot for use with N5242A. N5245-20130 is the right foot and N5245-20131 is the left foot for use with N5244A/45A.
- Screw – 0515-2317 (rear feet to the test set)

Front Panel Cabling

The millimeter-wave modules are placed on the work surface in front of the PNA-X and head controller as shown in [Figure 1](#) and [Figure 2](#) on page 3.

Connect the front panel interconnect cables from the PNA-X to the N5261/62A Millimeter Head Controller. The rear panel jumper (SCR1 and SCR2) must be installed if you are using a front panel SRC cable (W1 - W4). Refer to [Table 1](#) on page 7 for your specific option cable part numbers. Refer to [Figure 12](#) and [Figure 13](#).

Figure 12 N5261A Front Panel Cabling

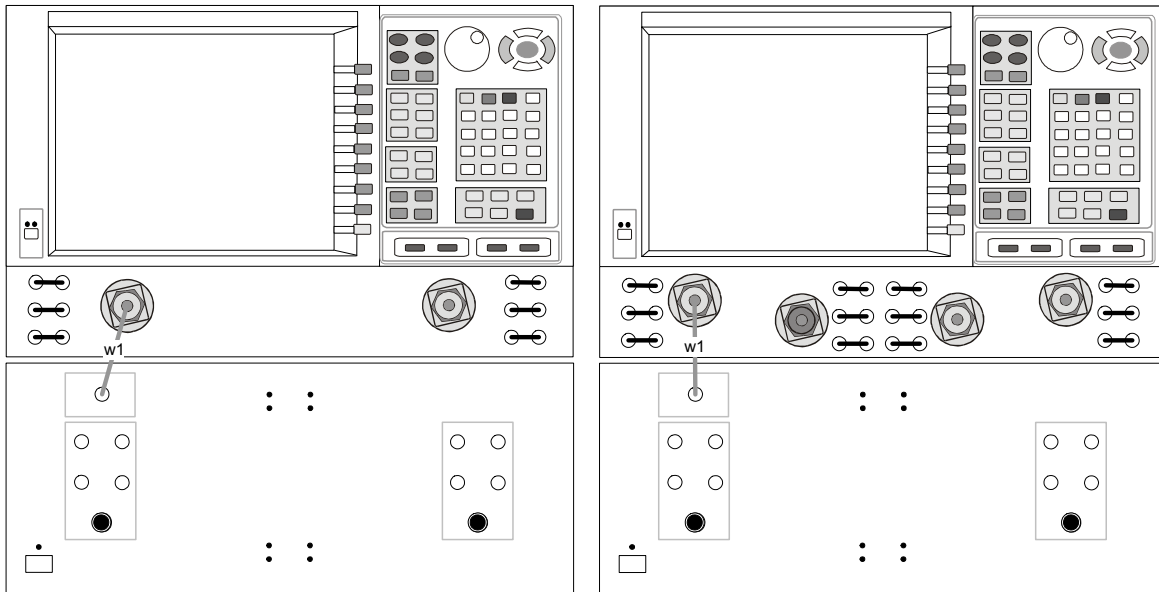

Figure 13 N5262A Front Panel Cabling (Options 200 & 400)

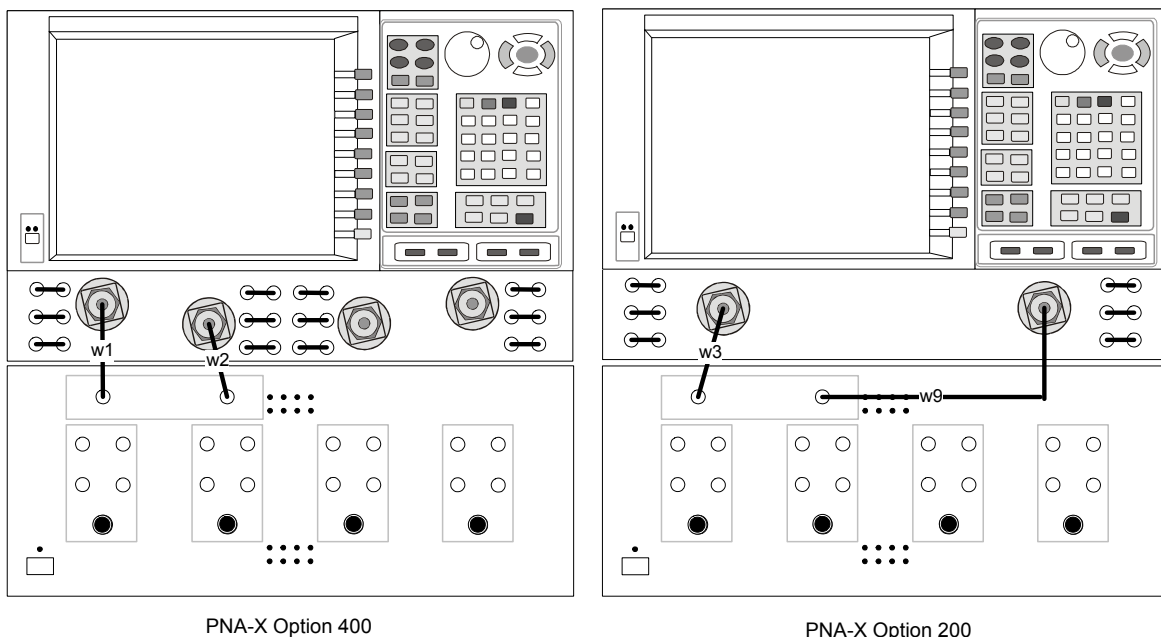
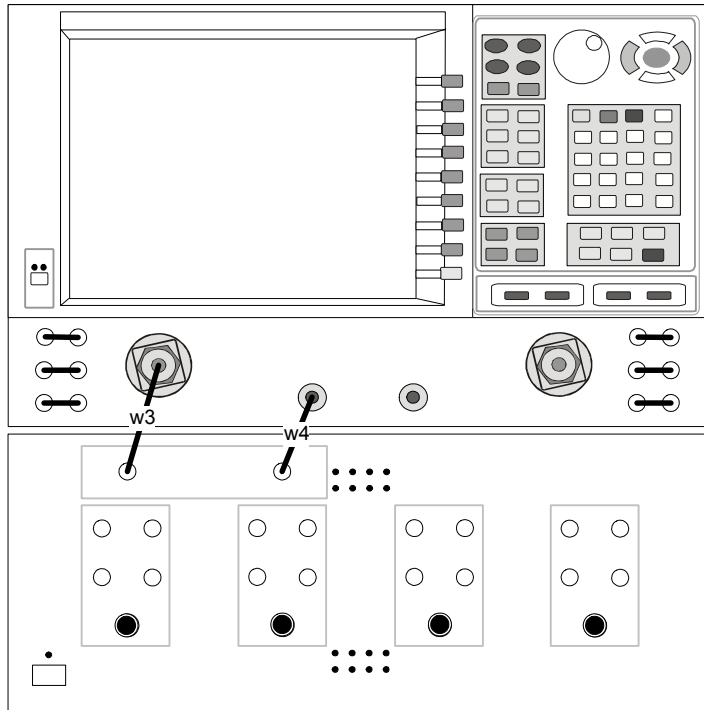

Figure 14 N5262A System RF Cables (PNA-X Options 219 & 223)



PNA-X Options 219, 223

Millimeter-wave Module Connections

Install the front-panel interconnections between the N5261/62A Millimeter Head Controller and the modules as shown in [Figure 15](#). Refer to [Table 1 on page 7](#) for your specific option cable part numbers.

If a millimeter-wave module is not installed on a port, a 50 Ohm termination (1810-0118) must be installed on the N5261A or N5262A LO OUT connector.

CAUTION Turn off the N5261/62A power when connecting or disconnecting the millimeter-wave module or damage can occur.

Attaching cables to the connectors is easiest if they are attached in the following sequence:

Table 9 Millimeter Head Controller Connections

Sequence	From: Millimeter Head	To: N5261A or N5262A
1	DC Power; +12V @ 1.5A (Bias)	DC Power ¹
2	RF INPUT; SMA connector	RF Out ²
3	LO INPUT; SMA connector	LO Out ²
4	Ref IF; SMA connector	REF IF
5	Test IF; SMA connector	TEST IF

1. A separate DC supply is recommended if modules are greater than 5 meters from the controller. A DC bias power cable with banana plug connectors (N5260-60052) for use with a separate power supply, such as E3615A are available.
2. Option 505 or 503 cable sets require external amplifiers, due to the RF insertion loss of the LO and RF signals into the module. Refer to [“Compatible Millimeter-wave Modules” on page 10](#).

Figure 15 N5262A System Millimeter-wave Module Connections

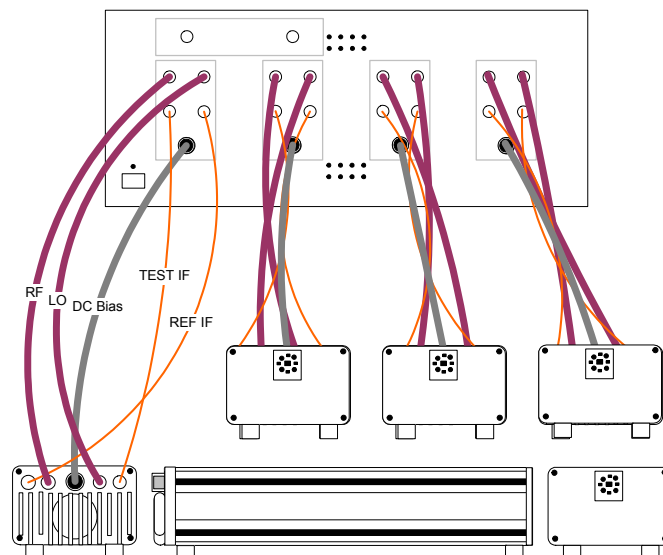

Rear Panel Cabling

1. Connect the PNA-X rear panel IF INPUTS to the test set IF OUTPUTs (D, C, R, B and A), using cables (W8, 5061-9038).
2. Connect the test set LO IN to the PNA-X LO OUT (J5), using cables (W8, 5061-9038).
3. Connect the test set I/O cable (8120-6818) from the PNA-X to the N5261/62A Millimeter Head Controller.
4. If you are using the rear panel connections remove the jumpers (E8356-20072). Connect the PNA-X SW SRC OUT (J11) to the N5261/62A rear panel SRC 1 RF IN, using cable (W5 or W6, 5061-9038). Connect the PNA-X SW SRC OUT (J8) to the SRC 2 RF IN on the N5262A rear panel. If you are using the front panel cable connections, ensure that the jumpers (E8356-20072) are installed. Refer to [Figure 16](#) and [Figure 17 on page 30](#).

Figure 16 2-Port Rear Panel Cabling

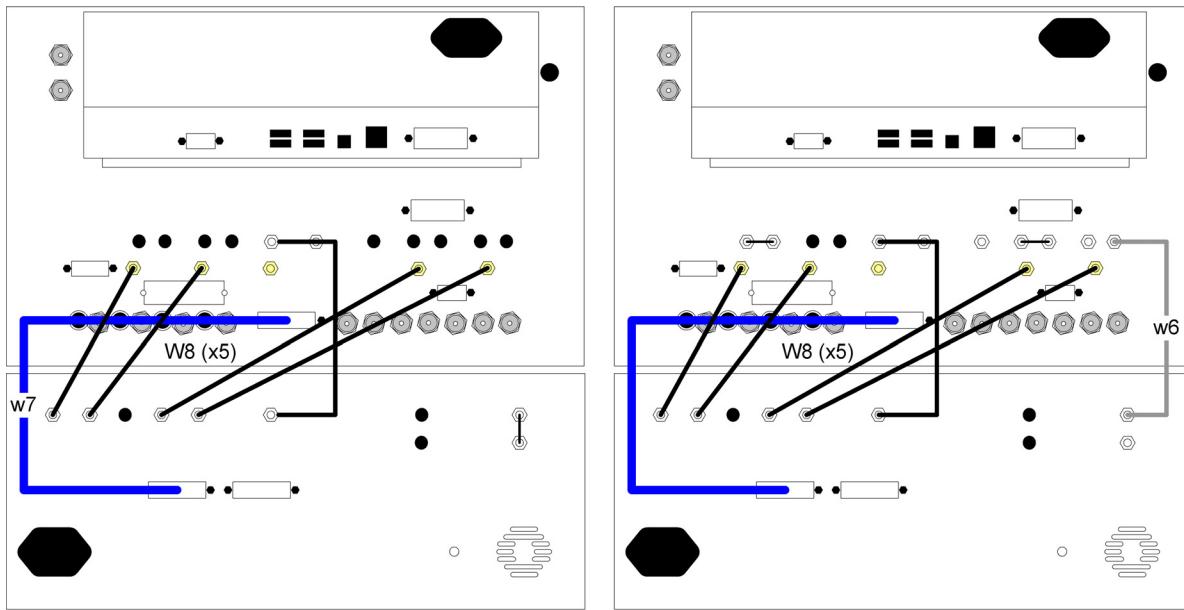

N5261/62A with PNA-X Opt 200

N5261/62A with PNA-X Opt 219 and 224

Figure 17 4-Port Rear Panel Cabling

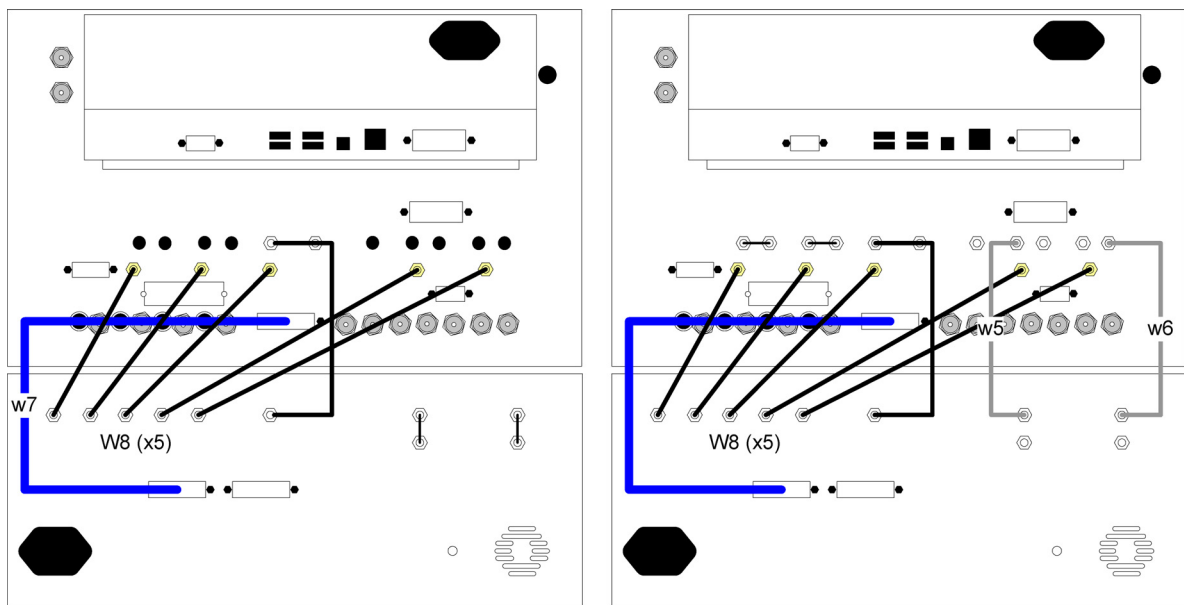

N5262A with PNA-X Opt 400

N5262A with PNA-X Opt 419 and 423

Controlling the N5261/62A with the PNA-X

This section will describe how to setup and operate the N5261/62A Millimeter Head Controller with the N5242A.

The N5261/62A Millimeter Head Controller is considered a “slave” instrument. A PNA-X must be used to control the Test Set.

- PNA-X firmware revision:
N5242A ≥ A.08.20.04.
N5244A/45A ≥ A.08.60.07

Visit our website for firmware revision and downloads.

<http://na.tm.agilent.com/pna/firmware/firmware.htm>

CAUTION Before switching on this instrument, make sure the supply voltage is in the specified range.

PNA-X Millimeter Mode

The PNA-X multiport mode selects the application that will enable the PNA-X to control the N5261/62A Millimeter Head Controller. The PNA-X millimeter mode allows you to configure the system for the millimeter-wave module you are using. Refer to the PNA-X Help system for more information.

The PNA-X Option 020 (IF Input) is required for in the PNA-X for the Millimeter mode of operation.

Figure 18 Example: N5242A Options

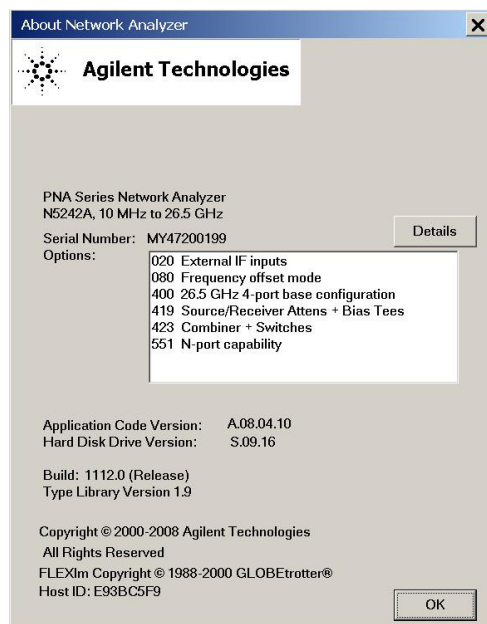

How to Access Millimeter Mode 1. The Option 020 must be installed for Millimeter capability. To access the millimeter application select [**System**] > **Configure** > **Millimeter Module**. See [Figure 19](#).

Figure 19 Selecting Millimeter Mode

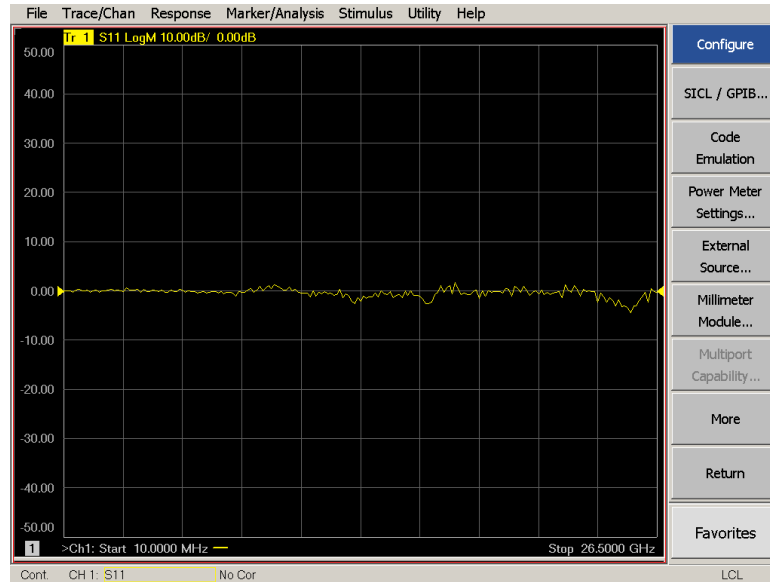

2. Select **New**. See [Figure 20](#).

Figure 20 Millimeter Module Configuration

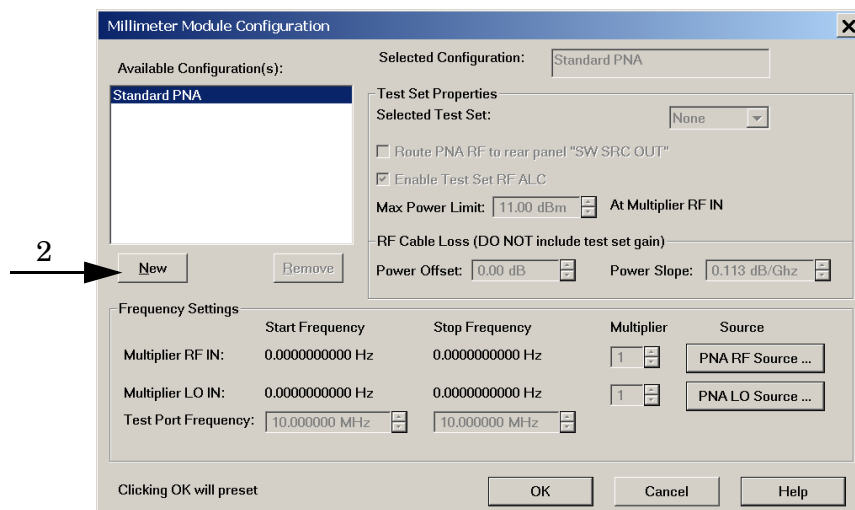

- In the “**Selected Configuration**” dialog enter a title, such as WR15 or Millimeter PNA-X. See [Figure 21](#).
- Select the test set you are using from the drop down menu (N5261A or N5262A).

Figure 21 **Select Test Set**

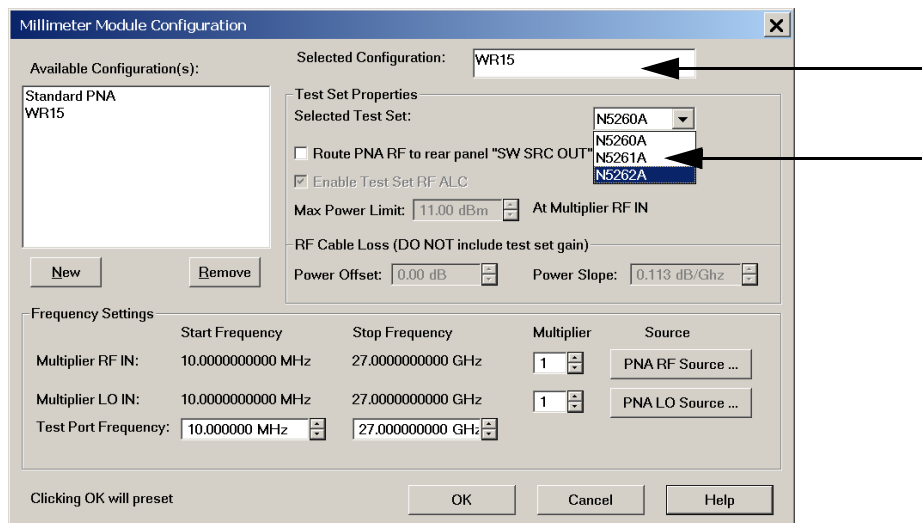

- Select “**Route PNA RF to rear panel “SW SRC OUT”** if you have connected the PNA-X SW SRC OUT to the test set rear panel SRC IN. Do *not* select “**Route PNA RF to rear panel “SW SRC OUT”** if SRC IN is connected on the front panel.
- The ALC mode is normally turned *on* to ensure that the module is operating at the proper level. Clear “**Enable Test Set RF ALC**” if you would like to set the power level into the millimeter-wave module. This would be useful to test amplifiers and other devices that require lower than the maximum power delivered by the millimeter-wave module. The ALC is turned *off* when in pulse mode. Use care when ALC mode is off to prevent the module from being over-driven.

If “**Enable Test Set RF ALC**” is enabled the power will be set at +11 dBm, the default maximum power limit. You may adjust the power in the “**Max power Limit**” dialog box. The power level indicated in the “Max power limit” dialog box is the output power level of the N5261/2A RF OUT ports to the modules.

7. Enter the **Multiplier RF IN** number. Example: (WR15 = 4), [Table 10](#).
8. Enter the **Multiplier LO IN** number. Example: (WR15 = 5), [Figure 22](#).
9. In the “**Test Port Frequency**” dialog box enter the **Start** and **Stop Frequency** of the millimeter-wave module. Example: (WR15 = 50 GHz/75 GHz)
10. Press **Ok**. The PNA will preset for millimeter operation.

The Millimeter-wave PNA module are now the source and receiver ports of the system. The PNA-X ports 1 thru 4 are no longer enabled.

Figure 22 New Configuration System Name

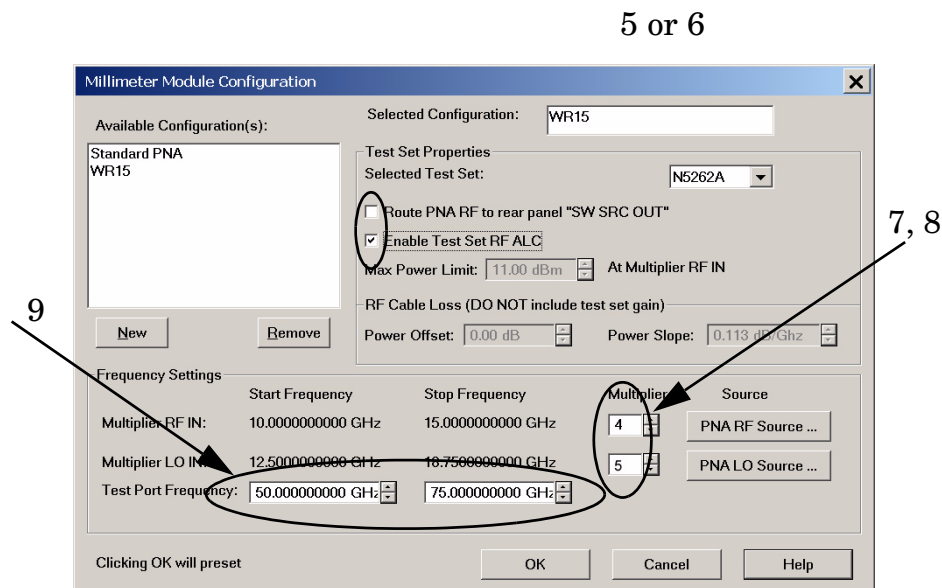

Table 10 RF and LO Harmonic Multipliers

Band ¹	Freq Range of Operation (GHz)	RF Freq Range (GHz)	RF Harmonic Multiplier	LO Freq Range ± IF Offset (GHz)	LO Harmonics Multiplier
WR-15	50 to 75	12.5 to 18.8	4	10.0 to 15.0	5
WR-12	60 to 90	10.0 to 15	6	12.0 to 18.0	5
WR-10	75 to 110	12.5 to 18.4	6	9.3 to 13.8	8
WR-08	90 to 140	7.5 to 11.7	12	11.2 to 17.5	8
WR-06	110 to 170	9.1 to 14.2	12	11.0 to 17.0	10
WR-05	140 to 220	11.6 to 18.4	12	14.7 to 18.0	12
WR-04	170 to 260	8.5 to 13	20	12.1 to 18.6	14
WR-03	220 to 325	12.2 to 18.1	18	12.2 to 18.1	18

1. For other waveguide band information refer to N5256/57/58A Millimeter-wave Module Users Guide (N5256-90001).

Calibrating the System

NOTE In millimeter mode the receivers are always active for all ports, therefore the receiver LED port indicators will always be illuminated. Depending on the ports selected, the source LEDs maybe on or off.

This section will provides information to calibrate the network analyzer millimeter-wave system, using waveguide mechanical standards. The millimeter-wave system can be used to make calibrated S-parameter measurements. Refer to the PNA-X Help menu for further information.

1. Set the systems **Frequency Range**, **IF Bandwidth** and **Number of Points** to be used in your measurements.
2. Press **[CAL] > CAL Wizard** on the PNA-X.
3. Select **SmartCal (GUIDED Calibration)**, or **UNGUIDED Calibration > Next**.

Figure 23 Cal Method

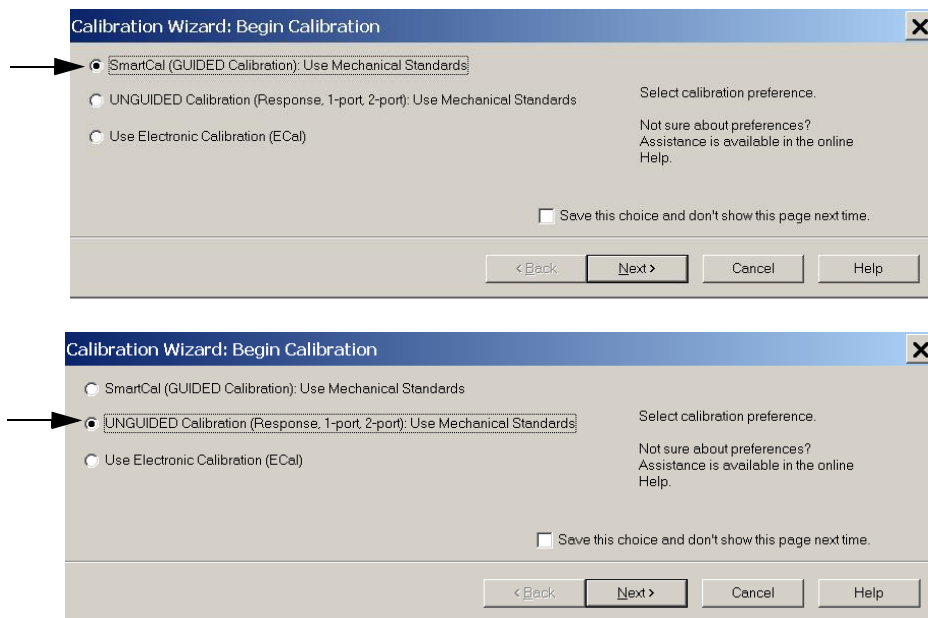

4. Select the ports to be calibrated > **Next**.

Figure 24 Select Ports for Smart Cal

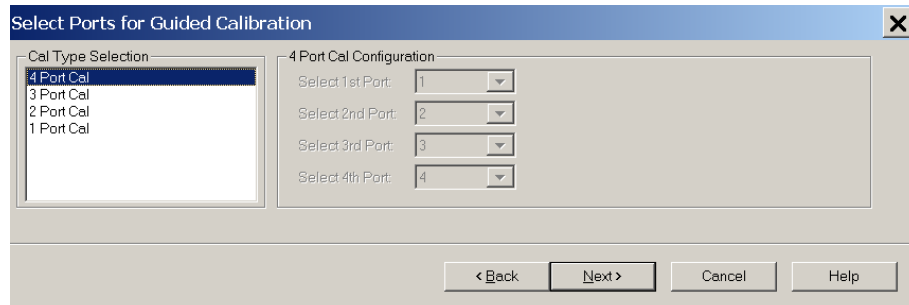

5. Press **View/Select Cal Kit** for an Unguided Cal.

Figure 25 Select Ports for Unguided Cal

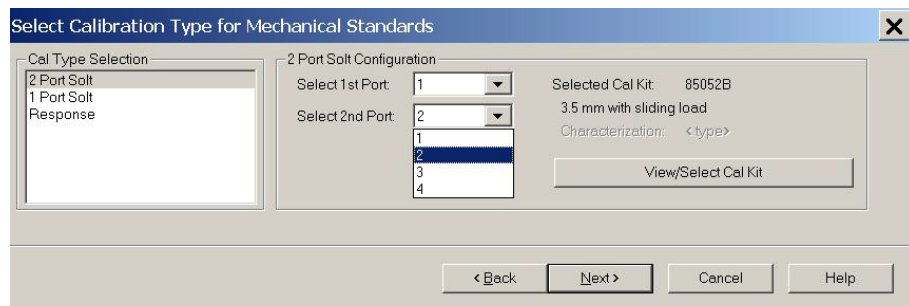

6. Select the required Cal Kit from the drop-down menu for the waveguide band you are using. If you are performing an unguided Cal, select **SOLT** or **TRL** in “Choose class type”. If your calibration kit is not in the drop-down list import your calibration data, refer to [Figure 37 on page 50](#).

7. Press **Ok > Next**.

Figure 26 Unguided Cal Kit List

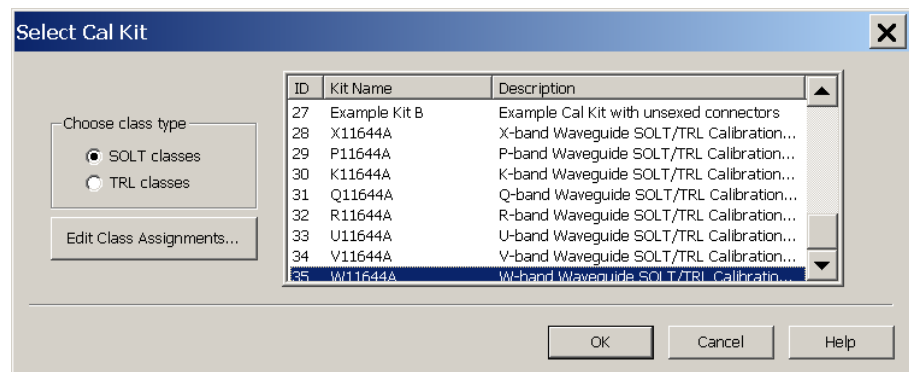
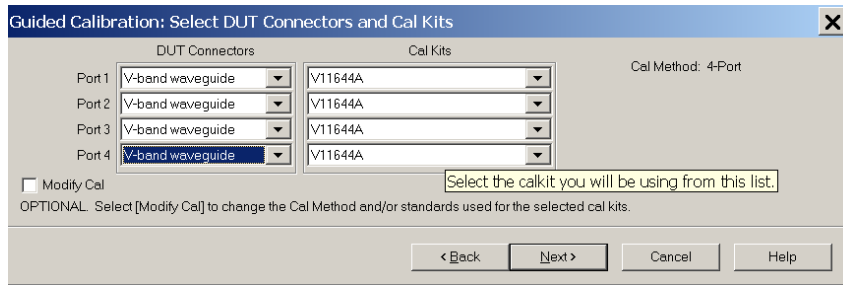

Figure 27 Guided Cal Kit List (SmartCal)



8. Press the individual keys to measure each Mechanical Standard or Thru. Follow the prompts for Smart Cal.
9. Press **Next** when all of the Mechanical Standards have been measured.

Figure 28 Unguided Cal Mechanical Standards

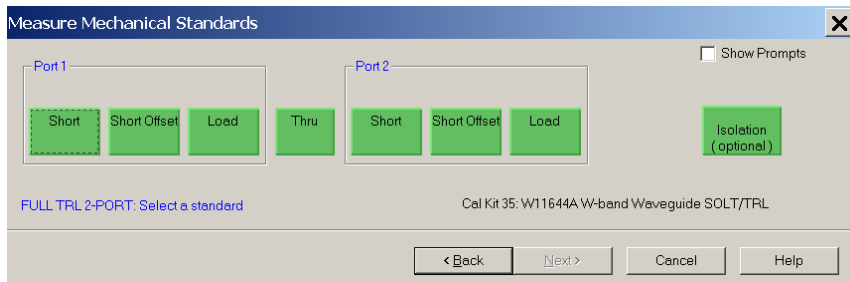
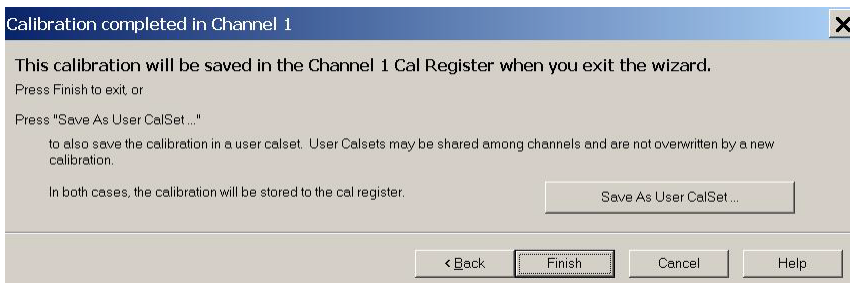

Figure 29 Smart Cal Prompt



10. Press **Save As User CalSet** to save the calibration.

Figure 30 Save Cal



Operational Check

There are two methods to verify your system.

- Non-System Operational Check for the N5261A or N5262A. Verifies that the test set is operating with no system components required.
- System Operational Check for the system. Verifies the configured system is operating correctly. Requires all system components and calibration kit.

Non-System Operation Check

The following procedure verifies the N5261/62A without system components.

Required Equipment

- PNA, PNA-L, PNA-X or equivalent 7 GHz to 20 GHz network analyzer with test set I/O interface
- Two RF flexible cables with 3.5 mm connectors (5062-6696 or equivalent)
- Three SMA adapters (female to female)
- Volt meter
- Power meter and sensor

Verifying the N5261/62A (Millimeter Head Controller)

1. Turn on the PNA, PNA-L or PNA-X and the N5261/62A.
2. Verify that the PNA, PNA-L or PNA-X is in “Standard PNA” mode.
3. Verify DC voltage supplies on each of the front panel DC power connectors. Pins 1 and 3 = +12 V, Pins 4 and 6 = ground

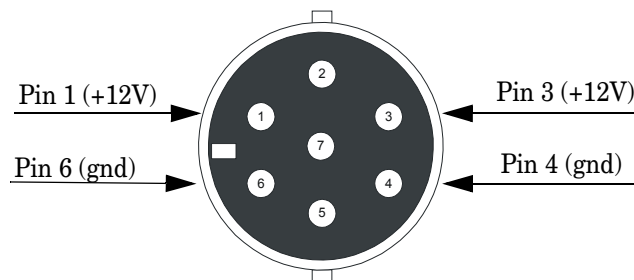

4. Measure the LO OUT and SRC1 & SRC2 RF paths:
 - a. Connect the test set I/O cable from the PNA to the N5261A or N5262A.
 - b. Press **[Preset]**.
 - c. Press **[Freq] > Start > [7 GHz]**.
 - d. Press **Stop > [20 GHz]**.

- e. Press **[Power]** > **[-30]** > **[Enter]**.
- f. Press **[Meas]** > **S12**.
- g. Connect the RF cables with adapters to the PNA, PNA-L or PNA-X Port 1 and Port 2.
- h. Connect the two RF cables together with adapter.
- i. Normalize the trace. Press **[Memory]** > **Normalize**. You will see a flat line at 0 dB.
- j. Remove the adapter from the cables and connect the Port 2 cable to the rear panel LO IN.
- k. Connect the PNA, PNA-L or PNA-X Port 1 to test set port LO OUT and verify the LO Output power. Refer to [Table 10](#) and [Figure 31](#). Repeat this step for each LO OUT Port.
- l. Remove the SRC1 IN to SRC1 OUT rear panel jumper.
- m. Connect the PNA, PNA-L or PNA-X Port 1 to the test set SRC1 IN.
- n. Connect Port 2 to the rear panel SRC1 OUT.
- o. Verify the power loss. The trace typically slopes down at -1 dBm to -2 dBm. Refer to [Table 10](#).
- p. Remove the SRC2 IN to SRC2 OUT rear panel jumper and repeat for SRC2 IN and SRC2 OUT.

Table 11 SRC1/2 and LO RF Path Measurement

From the Rear Panel	To the Front Panel	Measure Gain/Loss
SRC1 OUT	SRC1 IN	-1 dB (±1 dB)
SRC2 OUT (N5262A)	SRC2 IN (N5262A)	-1 dB (±1 dB)
LO IN	LO OUT	+30 dB (±5 dB)

Figure 31 LO Output Power

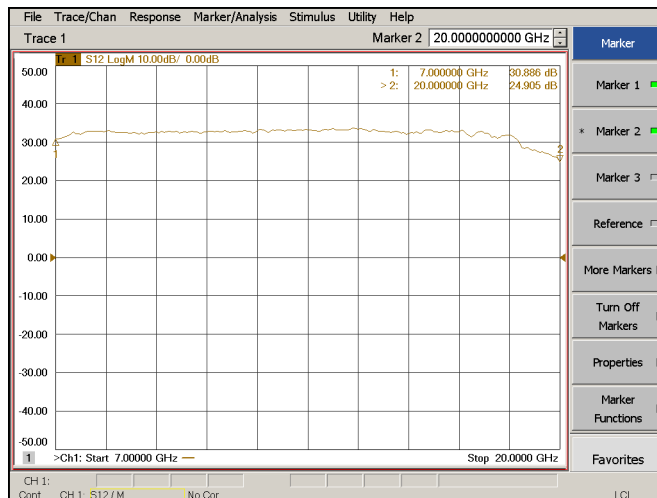

5. Measure RF OUT

- a. Re-install the SRC1 IN to SRC1 OUT rear panel jumper.
- b. Press **[Preset]**.
- c. Press **[Freq] > Start > [7 GHz]**.
- d. Press **Stop > [20 GHz]**.
- e. Press **[Power] > [-20] > [Enter]**.
- f. Press **[Meas] > S12**.
- g. Connect the two RF cables together with adapter.
- h. Normalize the trace. Press **[Memory] > Normalize**.
- i. Remove the adapter and connect Port 2 to SRC1 IN.
- j. Connect the PNA-X Port 1 to the test set RF OUT.
- k. Select **Trace/Chan > Channel > Hardware Setup > Interface Control**. Select **Enable Interface Control** and type the I/O command **0.1** in the Test Set I/O Control (addr.data) panel > **OK**. Verify the power level using [Table 12 on page 41](#) and [Figure 32 on page 41](#).

NOTE The PNA, PNA-L or PNA-X Series Network Analyzer comes with the Interface Control application. Information regarding this application can be found in the PNA's **Help System Menu, InterfaceControl**. The application is shown below.

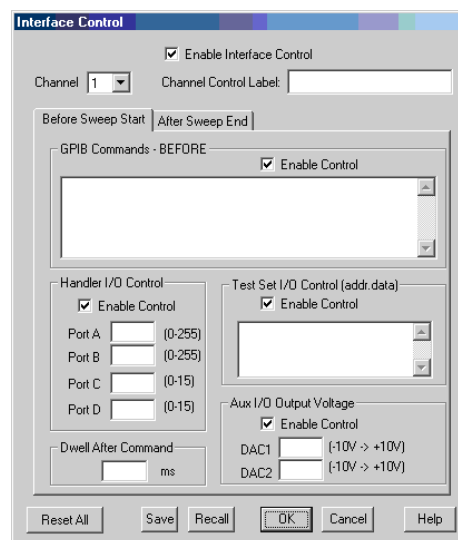
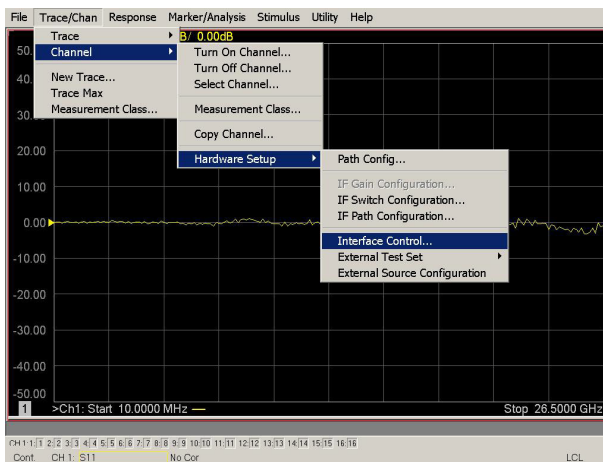

- l. Repeat [step j](#) and [step k](#) for Ports 2, 3 and 4 RF OUT. When verifying Ports 3 and 4 move the Port 2 cable to SRC 2 IN. Refer to [Table 12](#) for the I/O command.
- m. Send command 32.1 to turn ALC *off* for Ports 1 or 2. Confirm the RF power level increases on Port 1 when ALC is turned off. Repeat for Port 2.
- n. Send command 32.2 to turn ALC *off* for Ports 3 or 4. Confirm the RF power level increases on Port 3 when ALC is turned off. Repeat for Port 4.

ALC Off Commands:

- 32.0 turns ALC *on* for SRC 1 IN (Ports 1 and 2) and SRC 2 IN (Ports 3 and 4)
- 32.1 turns ALC *off* for SRC 1 IN (Ports 1 and 2)
- 32.2 turns ALC *off* for SRC 2 IN (Ports 3 and 4)

Table 12 I/O Command for RF Paths

From the Front Panel	To the Front Panel	Command	Gain
SRC 1 IN	Port 1 RF OUT	0.1	20 dB (±5 dB)
SRC 1 IN	Port 2 RF OUT	0.2	20 dB (±5 dB)
SRC 2 IN (N5262A)	Port 3 RF OUT	0.16	20 dB (±5 dB)
SRC 2 IN (N5262A)	Port 4 RF OUT	0.32	20 dB (±5 dB)

Figure 32 RF Output Power

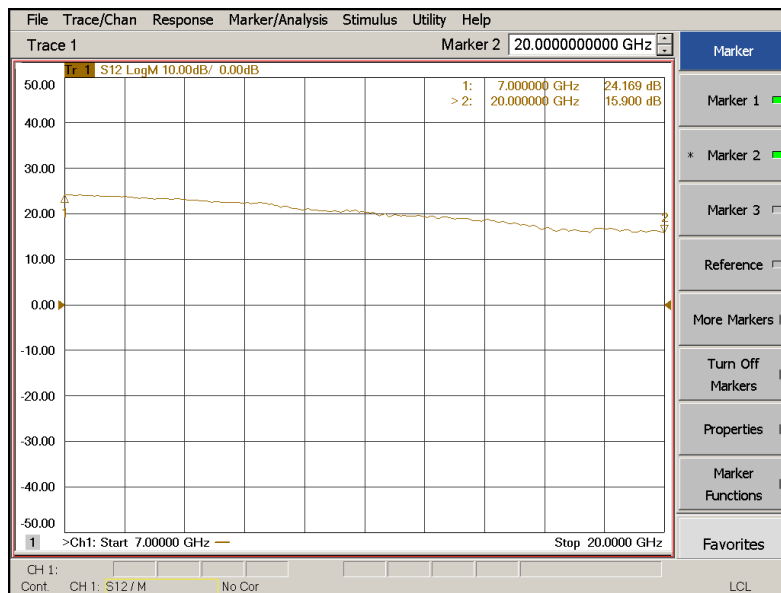

6. Measuring the TEST IF and REF IF Inputs to A, B, C, D and R Outputs. Refer to [Table 13 on page 43](#).
 - a. Connect the test set I/O cable from the PNA to the N5261A or N5262A.
 - b. Press **[Preset]**.
 - c. Press **[Freq] > Start > > [10 MHz]**.
 - d. Press **Stop > [20 MHz]**.
 - e. Press **[Power] > [-20] > [Enter]**.
 - f. Press **[Measure] > S21**.
 - g. Connect the two RF cables together with adapter.
 - h. Normalize the trace. Press **[Memory] > Normalize**.
 - i. Remove the adapter and connect the PNA, PNA-L or PNA-X Port 1 to the front panel test set Port 1, TEST IF.
 - j. Connect Port 2 to the test set A IF OUT on the rear panel.
 - k. Select **Trace/Chan > Channel > Hardware Setup > Interface Control**. Select **Enable Interface Control** and type the I/O command **16.8** in the Test Set I/O Control (addr.data) panel > **OK**. Verify the power level using [Table 13](#).
 - l. Repeat [step j](#) and [step k](#) for each TEST IF port.
 - m. Connect the PNA, PNA-L or PNA-X Port 1 to the front panel Port 1 REF IF.
 - n. Connect Port 2 to the rear panel D IF OUT.
 - o. Send the I/O command 16.8 and verify the power level. Refer to [Table 13](#).
 - p. Repeat [step m](#), [step n](#) and [step o](#) for each REF IF port.

Table 13 IF Path Measurement

From: TEST IF Front Panel	To: N5261A Rear Panel IF OUT	To: N5262A Rear Panel IF OUT	Command ¹	Gain
Port 1 TEST IF	A	A	16.8	0 dB (\pm 2 dB)
Port 2 TEST IF	B	B	16.4	0 dB (\pm 2 dB)
Port 3 TEST IF	n/a	C	16.2	0 dB (\pm 2 dB)
Port 4 TEST IF	n/a	D	16.1	0 dB (\pm 2 dB)
Port 1 REF IF	C	D	16.8	0 dB (\pm 2 dB)
Port 1 REF IF	n/a	R	16.33	0 dB (\pm 2 dB)
Port 2 REF IF	D	C	16.4	0 dB (\pm 2 dB)
Port 2 REF IF	n/a	R	16.2	0 dB (\pm 2 dB)
Port 3 REF IF	n/a	A	16.2	0 dB (\pm 2 dB)
Port 3 REF IF	n/a	R	16.56	0 dB (\pm 2 dB)
Port 4 REF IF	n/a	B	16.1	0 dB (\pm 2 dB)
Port 4 REF IF	n/a	R	16.20	0 dB (\pm 2 dB)

1. Commands are not required for the N5261A.

7. Verifying front panel LEDs.

- a. Connect the test set I/O cable from the PNA, PNA-L or PNA-X to the N5261A or N5262A.
- b. Send the TEST I/O command 64.17 and verify the Active LED (amber) and Port 1 Source (amber) & Receiver (green) Status LEDs are on.
- c. Send the TEST I/O command 64.34 and verify Port 2 S & R Status LEDs are on.
- d. Send the TEST I/O command 64.68 and verify Port 3 S & R Status LEDs are on.
- e. Send the TEST I/O command 64.136 and verify Port 4 S & R Status LEDs are on.
- f. Verify that the DC power LEDs are on.

NOTE In millimeter mode the receivers are always active for all ports, therefore the receiver LED port indicators will always be illuminated. Depending on the ports selected, the source LEDs maybe on or off.

System Operation Check

The System Operator's Check procedure confirms that the system functions normally. There are no hard specifications for the system measurement performance, only general guidelines are provided for evaluating the system operation results. The procedure can also be used to verify that your millimeter-wave modules are functioning properly.

Technical judgment is required when evaluating the results. The purpose of the System Operation Check is to detect significant degradations in the system that make the performance unacceptable. The calibration kit and test environment can affect the System Operation Check results. Refer to [“Site Preparation” on page 21](#).

When any part of the operator's check provides unsatisfactory results, refer to [“Troubleshooting” on page 67](#) to determine the cause of the problem.

Required Equipment

- A calibration kit compatible with the millimeter wave modules.

An Agilent or an OML calibration kit may be used with the system. The Agilent calibration kit definition is included with the PNA-X firmware. If an OML calibration kit is used with the millimeter-wave modules, the calibration kit definition must be entered in the PNA-X. To enter it, use the PNA-X function “Import Cal Kit” to import the .ckt file from a USB pen drive. (Search the Help index for the keywords “modify calibration kit.”) Include the calibration kit serial number in the calibration kit definition name/description.

- Waveguide extension sections (provided as accessories for the millimeter-wave modules or as part of a calibration kit).
- PNA-X Series Network Analyzer
- Millimeter-wave Module
- 3/32 Ball Driver
- 5/16 Open Wrench
- IF and RF System Cables
- N5261/62A Controller.

Information Required for the Operator's Check

- From the millimeter module user's guide (N5256-90001):
 - Note the specification for Coupler Directivity on the specifications page for the particular millimeter-wave module.
- From the data pages provided with the individual modules:
 - Output Power, Dynamic Range and Ref Port/Test Port graphs.
If this data is not available, contact Agilent and provide your model and serial numbers and Agilent will fax the page to you.
- From the calibration kit information:
 - Note the lower cut-off frequency for the wave guide ("TE 1.0" or "Min").
 - Note the length (in mm) of 1/4 wave offset shim.
 - Note the delay time for a waveguide section (50 mm = 167 picoseconds).

Table 14 Waveguide Loss Values

Band	Freq (GHz)	Loss Value
WR-2.2	325 to 500	500 Gohms/s
WR-03	220 to 325	428 Gohms/s
WR-05	140 to 220	167 Gohms/s
WR-06	110 to 170	157 Gohms/s
WR-08	90 to 140	105 Gohms/s
WR-10	75 to 110	64.85 Gohms/s
WR-12	60 to 90	39.73 Gohms/s
WR-15	50 to 75	24.23 Gohms/s

Preparing the PNA-X

1. Connect the PNA-X, the N5261/62A, and the millimeter-wave modules as described in ["System Setup with N5242A, N5244A or N5245A"](#) on page 22.
2. Turn On the N5261/62A and the PNA-X.
3. Configure the PNA-X for operation with the millimeter-wave modules. Refer to ["Controlling the N5261/62A with the PNA-X"](#) on page 31. For further information use the Help menu in the PNA-X. Search the Help index for the keyword "N5261/62A" to find the appropriate information. The RF and LO multiplier factors for the OML modules maybe read from the labels near the connectors on the modules, or in the N5256-90001 User's Guide.

Initial System Verification

This procedure verifies that the system is connected correctly and the modules, test set and PNA-X are operating properly.

1. Allow the system to warm up for at least 30 minutes.
2. Attach a waveguide extension section to each module's waveguide flange port to protect the modules waveguide connector.
3. Verify that the PNA-X is in Millimeter Mode and that the frequency range is correct for the waveguide band of the millimeter modules.
4. To verify the port as a receiver, perform the following steps:
 - a. Connect a short to module Port 1. The port can be left open, but the results may be slightly affected unless a waveguide SHORT or OPEN is connected to the module.
 - b. Press **[Avg] > IF Bandwidth > 10 > [Enter]**.
 - c. Display all four receivers on the PNA-X screen using the following menu selections: **[System] > Service > Utilities > Receiver Display**.
 - d. Compare the A,1 and R1,1 traces to the traces on the RefPort/TestPort page from OML for the millimeter-wave module on Port 1. The general level and shape should be similar but not necessarily identical.
 - e. If you are using more than one T/R module move the short to Port 2. If you are only testing one port proceed to [step 6](#).
 - f. Compare the B,2 and R2, 2 traces to the traces on the RefPort/TestPort page from OML for the millimeter-wave module on Port 2. The general level and shape should be similar, but not necessarily identical.
 - g. Repeat [step e](#) and [step f](#) for Port 3 and compare trace 3 C,3 and R3, 3.
 - h. Repeat [step e](#) and [step f](#) for Port 4 and compare trace 4 D,4 and R4, 4.

Figure 33 Port 1 and Port 2 Shorted Receiver Display

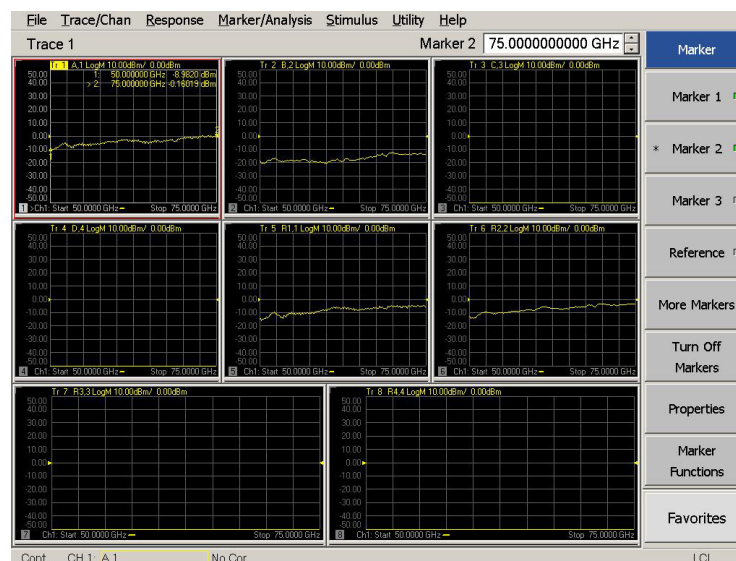

- i. Remove the short from the module.
- j. Connect the waveguide extension flanges of Port 1 module to Port 2, and Port 3 module to Port 4 (N5262A) to form through connections. Adjust the feet on the modules to insure the mating surfaces are properly aligned before connecting the waveguide flanges.
- k. Delete the trace 1, S11. Press **Trace/Chan > Trace > Delete Trace**.
- l. Press **[Preset] > Trace/Chan > Trace > New Trace**. Select S12 for systems with a T/R module on Port 2, and select S21 for systems with a T/R module on Port 1. (If the system has Port 3 and 4, select S34 for the system with T/R module on Port 4 and S43 if the system has a T/R module on Port 3). This test confirms that the modules are sourcing and receiving. Refer to your millimeter-wave modules power curve data, included with the millimeter-wave module.

NOTE S12 requires a T/R module on Port 2, and a T or T/R on Port 1.
 S21 requires a T/R module on Port 1, and a T or T/R module on Port 2.
 S34 requires a T/R module on Port 4, and a T/R module or T module on Port 3.
 S43 requires a T/R module on Port 3, and a T/R module or T module on Port 4.

Figure 34 Uncalibrated S12 and S21 with two T/R Modules

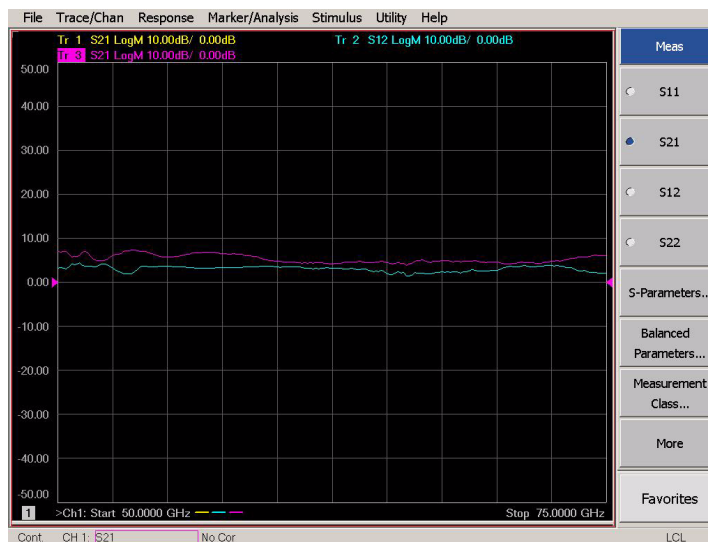

5. Check the dynamic range of each millimeter-wave module.
 - a. Set the PNA-X for 10 Hz IF BW, display S12, S21 traces, and S34, S43 traces or the traces for your system configuration. Refer to [step 4](#) > [step 1](#) for measurement trace information.
 - b. Press **[Avg]** > **IF Bandwidth [10]** > **[Enter]**.
 - c. Verify that both modules ports are connected together to form a through connection.
 - d. Normalize each trace. Select the trace and press **[Memory]** > **Normalize**.
 - e. Press **[Scale]** > **Reference Level > [-80]** > **[Enter]**. (each trace)
 - f. Disconnect the two module ports.
 - g. Connect a load or short to all module ports.
 - h. The S12, S21, S34 and S43 traces show non-calibrated system dynamic range. The dynamic range will vary depending on the modules used, and the configuration of the system. Refer to the N5256/57/58A Millimeter-wave Modules (N5256-90001) document for module performance information. Refer to [Figure 35 on page 48](#).

Figure 35 Dynamic Range Trace Example



- i. Remove the loads or shorts from the modules.

6. Verify the coupler directivity of each T/R module. This step is not required for T or T2 receiver modules.
 - a. Set the PNA-X for 10 Hz IFBW. Press **[Avg]** > **IF Bandwidth [10]** > **[Enter]**.
 - b. Display receiver A trace. Select **[System]** > **Service** > **Utilities** > **Receiver Display**. Refer to [Figure 33 on page 46](#).
 - c. Double click A1 window for a full display.
 - d. Connect a short to module Port 1.
 - e. Normalize the trace. Press **[Memory]** > **Normalize**.
 - f. Remove the short and connect a load to module Port 1.
 - g. Observe the response. This is the “rough” coupler directivity. The general level and shape of the trace should be similar to the directivity graph of your the module.
 - h. Repeat [step 6](#) for Ports 2 (B,2), 3 (C,3) and 4 (D,4).

Figure 36 Directivity Trace Example

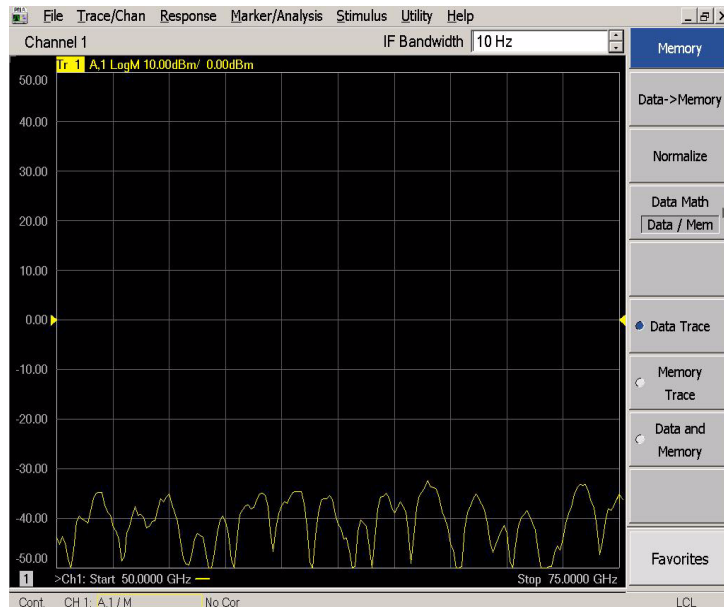

Verifying a Waveguide Section with a 2-Port Calibration

Measurement of a waveguide section, or a waveguide short will provide verification of the system.

1. Attach a waveguide extension section to each module's port, if not already installed. Use guide pins if available.
2. Allow the system to warm up for at least 30 minutes.
3. Perform a calibration, using the waveguide Cal kit. Refer to [“Caring for Waveguide Standards and Flanges” on page 13](#).
 - a. Press **[Preset]**.
 - b. Press **[Avg] > IF Bandwidth [10] > [Enter]**.
 - c. Set the media to “Waveguide”. Press **[Scale] > More > Media coax/WAVGD**. (Waveguide will be upper case, coax will be lower case).
 - d. Select **[Cal] > Start Cal > Cal Wizard**. Select **SmartCal (GUIDED Calibration) > Next**. Select the number of ports to be calibrated and the calibration kit you are using. Save the Cal for future use, if desired. The calibration software will guide you through the calibration procedure.
4. Measuring the waveguide section's length.
 - a. Verify waveguide minimum cut-off frequency of your Cal kit. Select **Response > Cal > More > Cal Kit**.
 - b. Select your Cal kit > **Edit Kit**.
 - c. Select the short or another standard from the list and select **Edit**.

Figure 37 Select Cal Kit

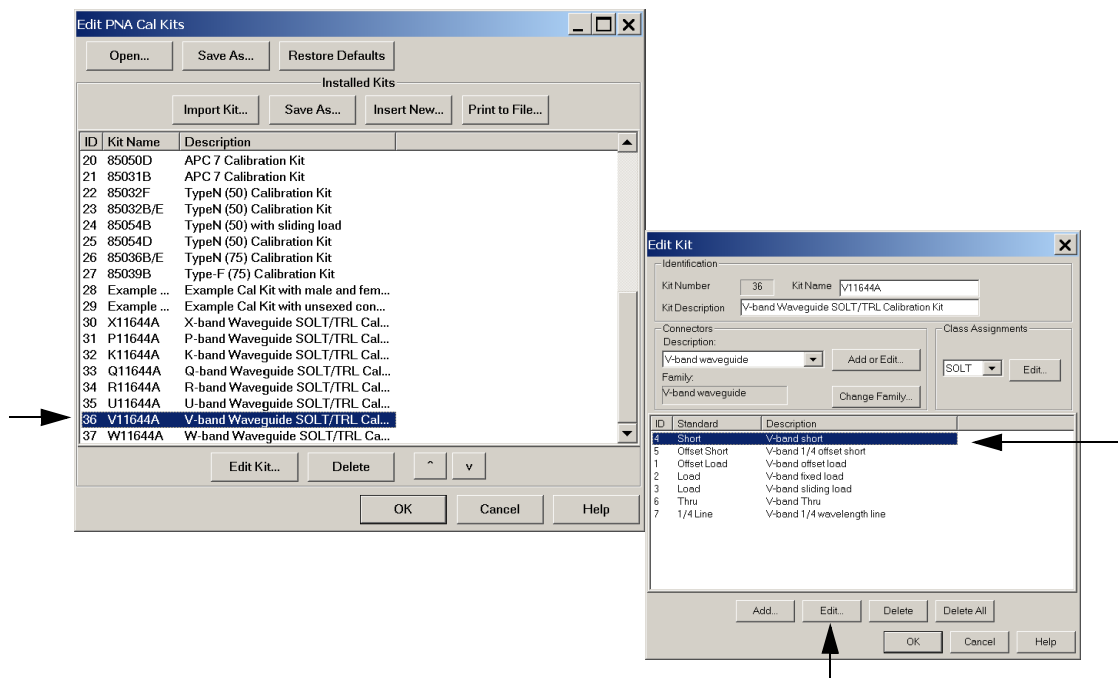

- d. Write down the “Min frequency” for use in [step e](#), press **OK**.

Figure 38 Select Standard

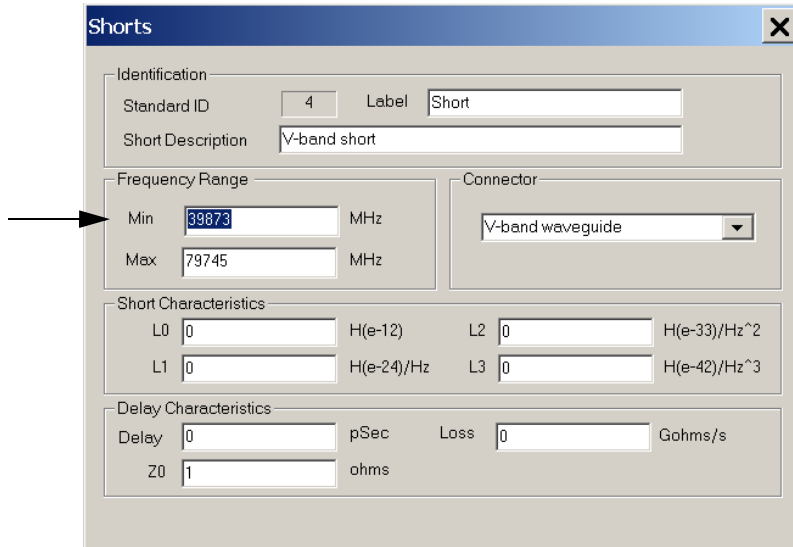

- e. Select **Response > Scale > Electrical Delay** and enter the “Min frequency” for the Cutoff freq. Select **Waveguide > OK**.

Figure 39 Electrical Delay

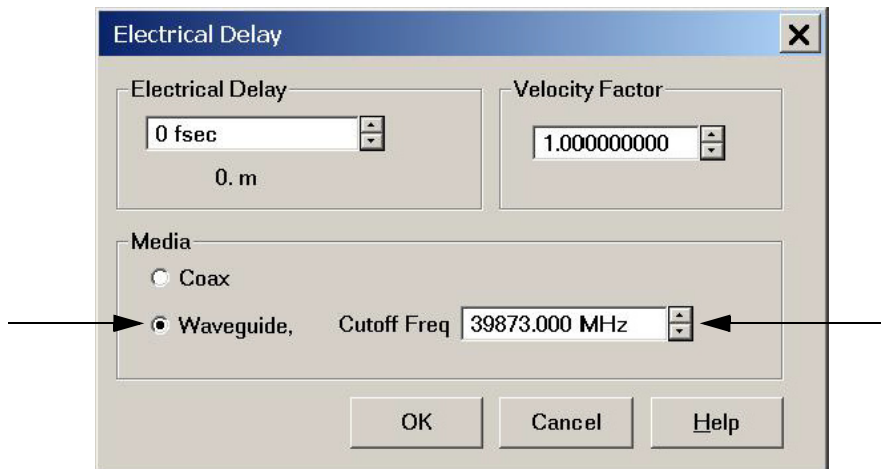

- f. Disconnect the modules and install the load from the Cal Kit to module Port 1.

- g. Display the Smith Chart for S11. Press **[Format] > Smith**. Verify that the response is in the middle of the smith chart.

Figure 40 Calibrated Load

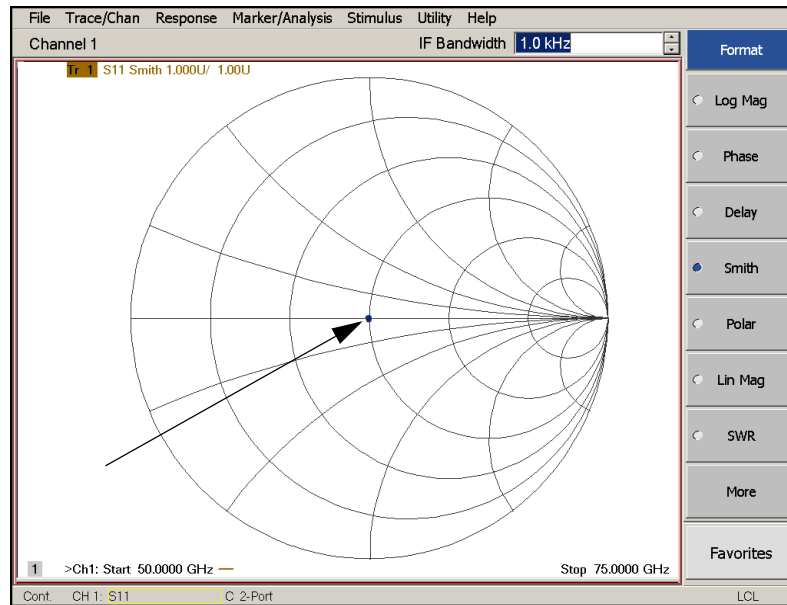

- h. Connect a short to module Port 1 and verify that the point has moved to the left side of the smith chart.

Figure 41 Calibrated Short

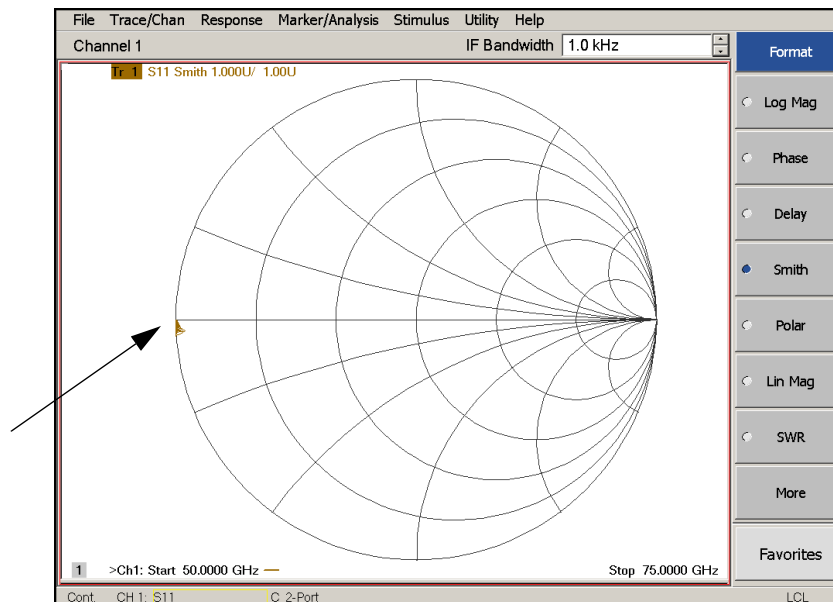

- i. Connect the 1/4 wave and a short to module Port 1. Verify the response (arc) on the right side.

Figure 42 1/4 Wave with Short Response

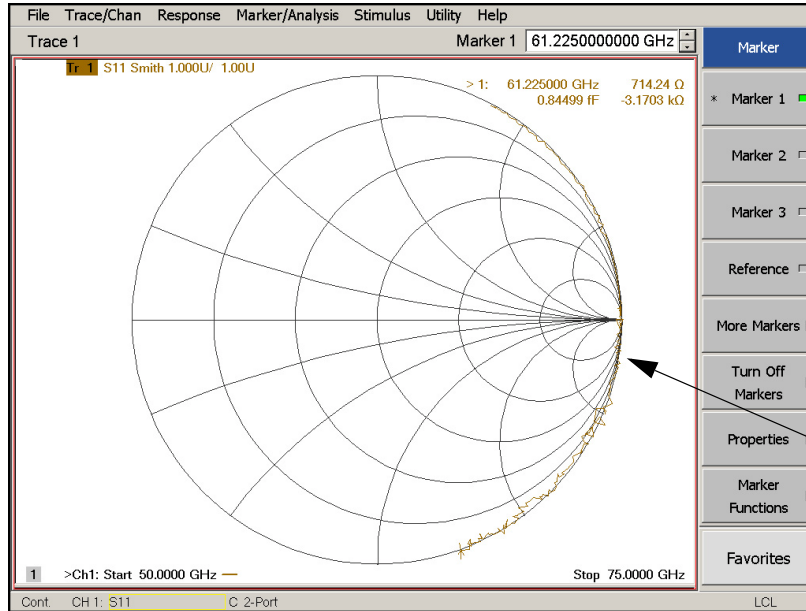

- j. Remove the 1/4 wave & short and connect the airline (or standard section) to Port 1.
- k. Connect the airline (or standard section) to Port 1.
- l. Connect a short to the open end of the airline.
- m. Press **[Marker]** > **Marker1**. The frequency of the marker should be approximately in the middle of the displayed frequency range.

n. Adjust electrical delay using the following menu selections:

- Select **Response > Scale > Electrical Delay** and increase the electrical delay until the trace is a small cluster on the left side of the Smith Chart's X-axis.
- Read the electrical and physical delay values. The physical delay should be approximately twice the length of the airline waveguide section in millimeters.

Figure 43 Waveguide Cutoff Frequency

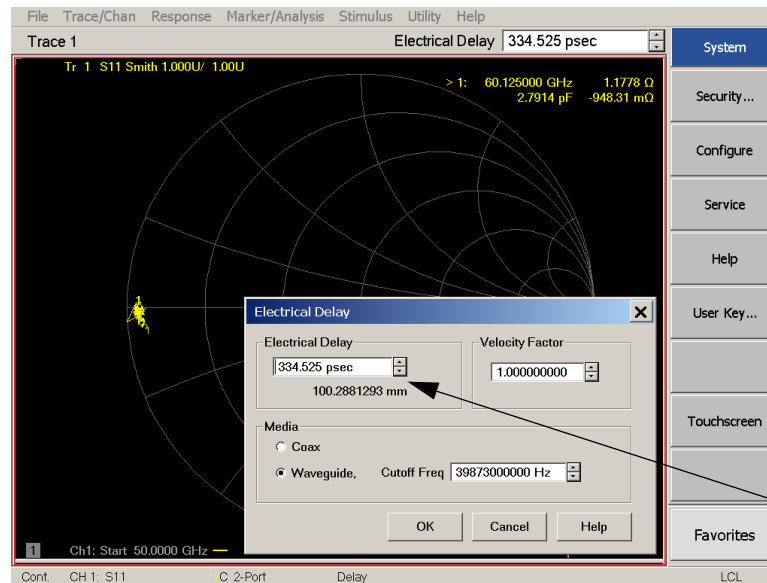
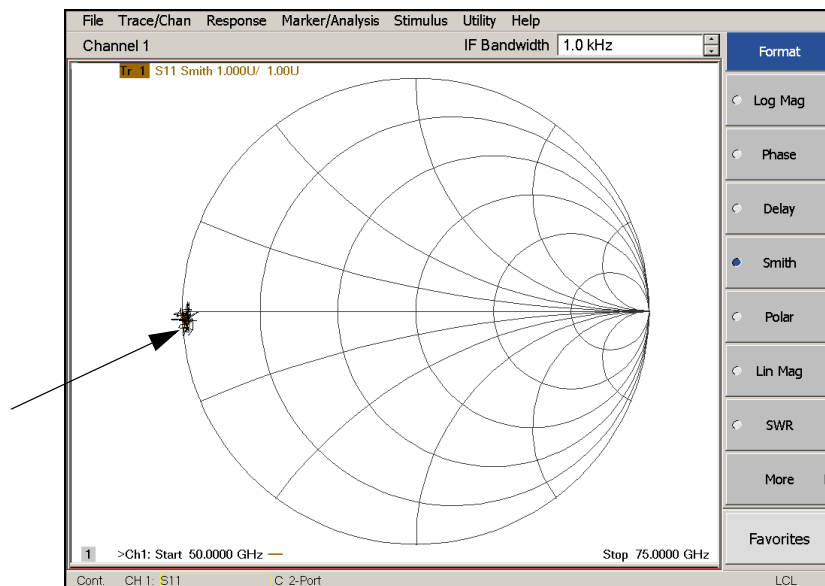

Figure 44 Small Cluster



- o. Add a 1/4 Offset Shim (with the short) to the airline. The Smith Chart trace should be an arc on the right side.
- p. Increase the electrical delay to minimize the length of the arc on the left side of the Smith Chart. Read the electrical and physical delay values. The physical delay should be approximately twice the length of the airline waveguide section + the 1/4 Offset Shim in millimeters.
- q. Remove the airline and install the short on module Port 1.
- r. Verify the return loss of the short. Press **[Meas] > S11 > [Format] > Log Mag.**
- s. Remove the short and connect the load.
- t. Compare the trace to the return loss specification of the load. Refer to the information in your Cal Kit.
- u. Repeat [step f](#) through [step t](#) for Ports 2, 3 and 4.

Verifying a Waveguide Short with a 1-Port Calibration

Measure the waveguide short. This requires only one port connected in the system. You will edit the calibrations kit definitions for Short + Null, Short + $\frac{1}{4}$ Offset, Thru + Null, and Thru+ $\frac{1}{4}$ Offset with loss value for the waveguide band. Refer to [Table 14 on page 45](#). The Load Offset definition must be updated. The SOLT standards class assignment calibration type must also be changed to perform a 1-Port calibration.

1. Attach a waveguide extension section to the module port, if not already installed. Use guide pins if available.
2. Allow the system to warm up for at least 30 minutes.
3. Import the Cal Kit definitions. Install the USB calibration data jump drive (included) into one of the PNAX USB ports. Press **CAL > more > Cal kit**, select **“Import Kit...”** and select from the jump drive directory, the Calibration kit file which usually has extension “.ckt” (as in “V03_AL_23.ckt”) The Kit will show at the bottom of the list.
4. Select the your kit in the list and select **Edit Kit**.

Figure 45 Edit PNA Cal Kits

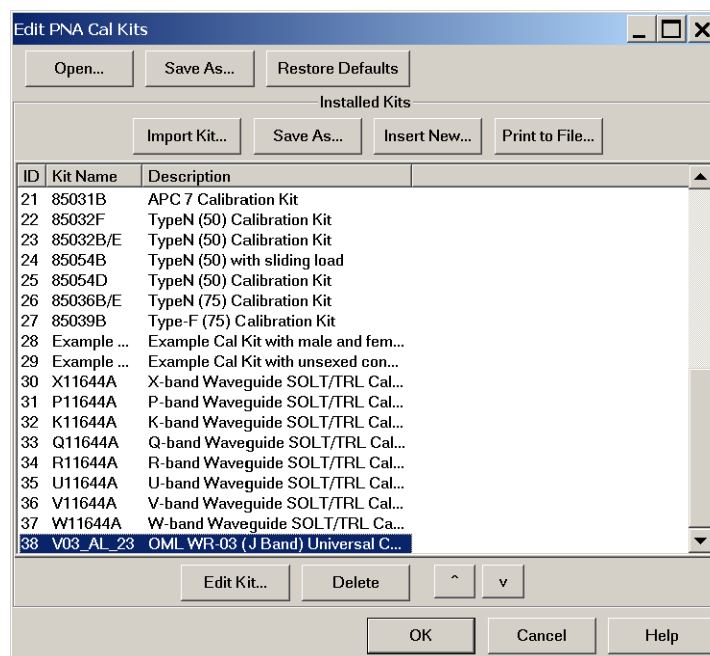

5. Select **Short + Null Shim** in the Edit Kit dialog box and select the **Edit** command button.

Figure 46 Edit Kit

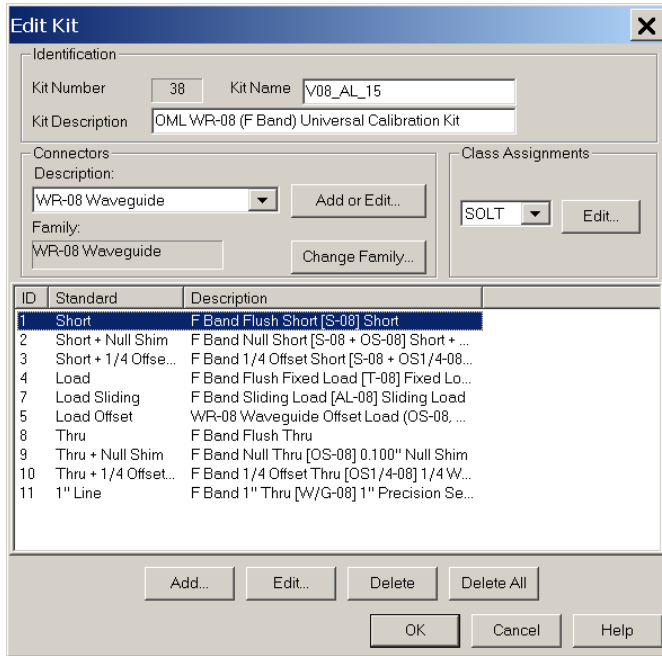

6. Enter the loss value for the waveguide band used. Select **APPLY** > **OK**.

Figure 47 Loss Value for Short + Null Shim

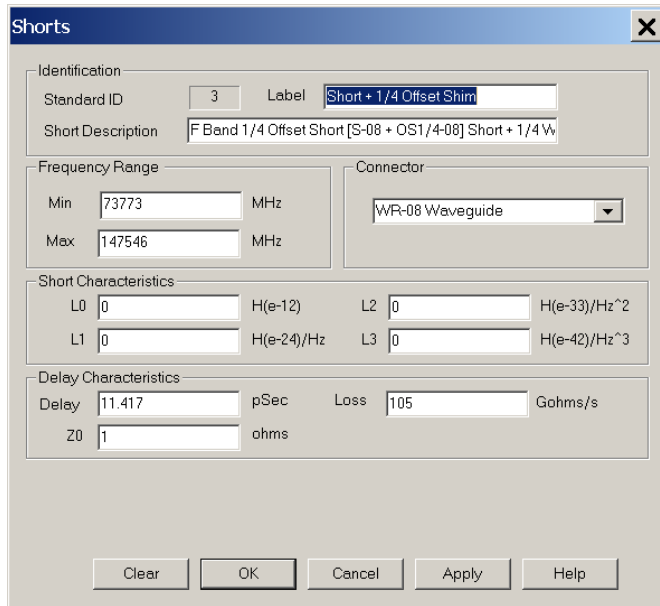

7. Repeat **step 5** and **step 6** for the **Short + 1/4 Offset, Thru + Null Shim, and Thru +1/4 Offset**.

8. Select **Load Offset** in the Edit Kit dialog box. Verify the Offset Load Definitions as in [Figure 48 on page 58](#).

Figure 48 Load Offset Edit

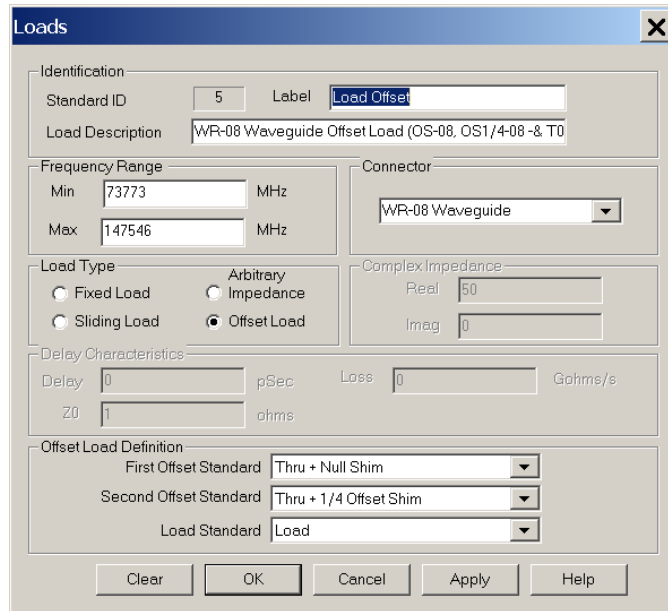

9. Verify or select **SOLT** in the Class Assignment panel and select **Edit**. Refer to [Figure 46 on page 57](#).
10. Select **S11A** Open (or Offset Short), verify that **Short+1/4 Offset** is in the Selected Standards panel.

Figure 49 S11A SOLT Class Assignments

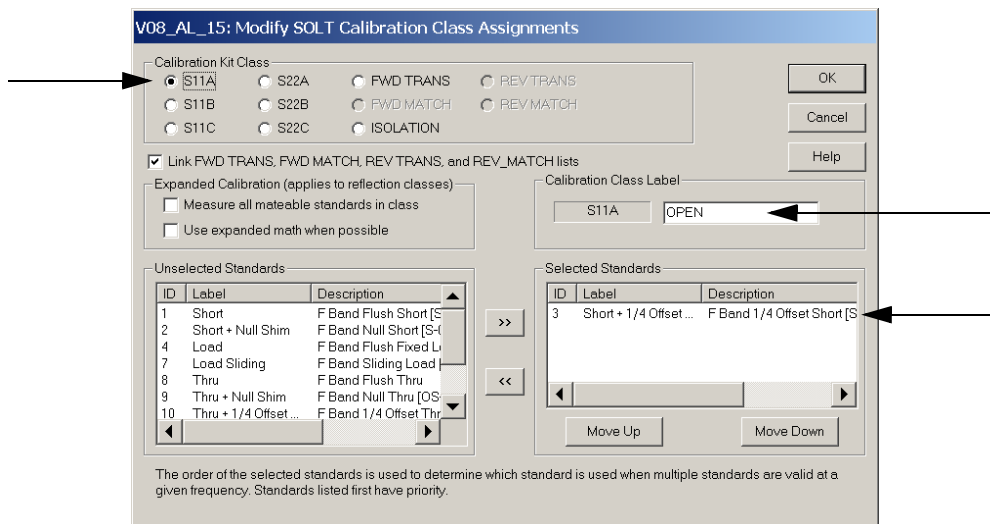

11. Select **S11B** Short, verify that **Short+Null Shim** is in the Selected Standards panel.

Figure 50 S11B SOLT Class Assignments

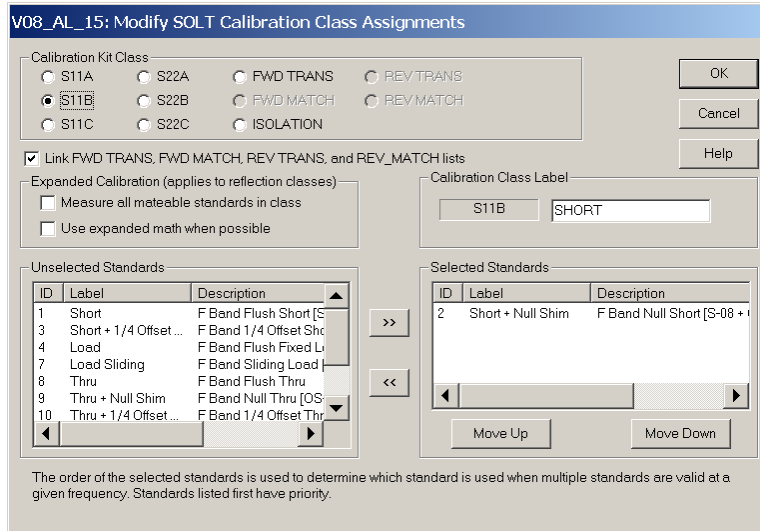

12. Select **S11C** Load, verify that **Load Offset** is in the Selected Standards panel. Remove all other standards in the Selected Standards list. Select **OK**.

Figure 51 S11C SOLT Class Assignments

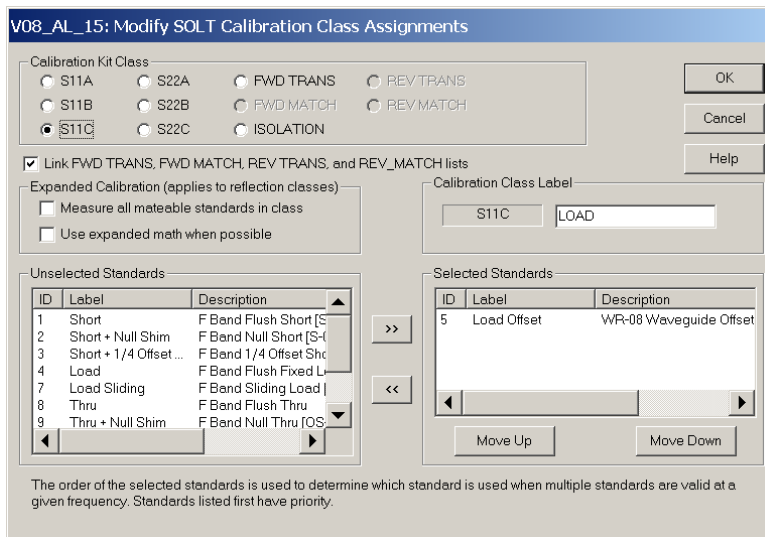

13. Perform a 1-Port calibration, using your waveguide Cal kit. Refer to “Caring for Waveguide Standards and Flanges” on page 13.

- a. Press **[Preset]**.
- b. Press **[Avg] > IF Bandwidth [10] > [Enter]**.
- c. Select **[Cal] > Start Cal > Cal Wizard**.
- d. Select **SmartCal (GUIDED Calibration): Use Mechanical Standards > Next**.
- e. Select the port you are using to be calibrated. The calibration software will guide you through the calibration procedure. You may want to save the Cal for future use.

14. Measure your Short.

- a. Connect the waveguide Short to Port 1 and setup a two window display. Press **[Display] > Stack 2x**.
- b. Measure S11 log magnitude in one window and S11 Phase Delay in the second window. Set the Phase Delay Offset to 180 degrees. Press **[Format] > Phase > Scale > Phase Delay > [180] > Enter**.
- c. Verify Return Loss and Phase Delay of the Short.

Theory of Operation

Functional Block and Assembly Information

The N5261A/62A routes PNA-X LO and RF signals to a millimeter-wave module. This allows the PNA-X to up-convert for a millimeter-wave source and down-convert a received millimeter-wave frequency to an IF frequency < 20 MHz. It also provides the DC power for the millimeter-wave module. The following components are used in the N5261/62A. Refer to the block diagrams, [Figure 52](#) through [Figure 55](#) beginning on [Page 64](#).

Test Set Controller Board (N5261-60006)

The Test Set Control Board (N5261-60006) is a surface mount, printed circuit assembly (PCA) that provides a connection to the power supply, and the PNA-X Test Set I/O. The PNA-X sends address and data commands which are read by the Test Set Controller for selecting the switch paths of the SRC1 and SRC2 RF and IF switch paths. The Test Set Controller board has a programmed FPGA and memory (NovRam) with model number and gain correction values for the Amplifiers and ALC circuits. Switch S1 is set to lock the memory after calibration is been loaded. The front panel “Active” and port LEDs are only *on* when the PNA-X has addressed the N5261/62A Millimeter Head Controller. The rear panel fan is *on* when the controller board supplies are operational.

Interface Board (N5261-60001)

The Interface board is installed on top of the Test Set Controller Board. It provides switch drive signals and voltage for the solid-state switches that select RF Inputs (SRC1 or SRC2) to one of the front panel RF Outputs ports. It provides switching from the front panel TEST IF and REF IF Inputs to the rear panel IF Outputs D/R2 C/R1, R, A, B. The Interface board also provides DC voltage and ALC control of the Amplifiers. The Interface board has a FPGA programmed device that enables N5261/62A Millimeter Head Controller operation.

LED Board (N5261-60005)

Two LED board assemblies are mounted to the front panel. The top LED board indicates the Source Path (amber/yellow color), or Receiver Path (green colored) shown as “S” and “R” for each Port. The bottom LED Board indicates the DC Power is *on* (green). If an over-current condition occurs on the millimeter-wave module the LED will be (amber/yellow), which could be a result of a shorted interface cable or damaged Millimeter-wave module. The LED board assemblies are connected to the Test Set Controller board by ribbon cables.

DC Power Board (N5261-60002)

The DC Power board provides connection to the power supply and self recovering fuses for each millimeter-wave module supply (+12 volt) on the front panel. The fuses are reset when the N5261/62A is turned *off*.

Power Supply (0950-4729)

The power supply (0950-4729) converts the AC line voltages to DC. This is an automatic line voltage selecting power supply. The DC supplies are connected to the test set control board through five wire harnesses to connectors J10, J11, J12, J13 and J14. The DC Power board is connected to connectors J5 and J8. The AC line voltage (100 to 240 V @ 50/60 Hz) is provided from the line module located on the rear panel.

Isolators (0955-1595)

Isolators are installed in the LO Output RF path for each port. These 10 watt isolators maximizes the LO power input to the millimeter-wave modules over a frequency range of 8 to 19 GHz.

LO Power Amplifier (5087-7290)

An amplifier installed in the LO Input path provides RF power required for the LO Out to the millimeter-wave module. This amplifier has an attenuator at its input to provide a good match and ensure the amplifiers output does not exceed +15 dBm.

RF and LO ALC Amplifier (5086-7523)

The Mod/Amp has adjustable gain that provides ALC leveling for the front panel RF and LO Outputs. Adjustments are made on each Mod/Amp to set the maximum output power to +12.5 dBm (R3). The output of each amplifier is connected to a coupler, and with a detector for ALC, the mod/amps provide RF and LO leveling. Gain values stored on the Test Set Controller board are used to provide a set RF and LO level when the ALC is turned *off* in the PNA-X Millimeter mode. Each Mod Amp has a Bias board (N5261-63003) installed on top that provides the power supply connection and circuitry for setting the gain of the amplifier (R3) and an SMB Input to the modulator.

Attenuator, 6 dB (0955-0243)

The 6 dB attenuators are used to attenuate the RF and LO power to the ALC detector to set the RF level for linear operation.

Attenuator, 3 dB (0955-0246)

The 3 dB attenuators are used in the SRC1 or SRC2 Mod/Amp Inputs to provide a good match and ensure it does not exceed +15 dBm.

Coupler (0955-0148)

Directional couplers with 10 dB coupling factor are used for ALC feedback for RF and LO Output leveling.

IF Gain Board (N5261-60008)

The IF Gain Board provides approximately 10 dB of gain from the front panel TEST IF and REF IF inputs to the rear panel IF OUTPUTS (D/R2 C/R1, R, A and B) in the N5262A. The IF paths are switched by the Interface Assembly (N5261-60001). The N5261A does not use the IF Gain assembly (N5261-60008) because the IF paths are connected directly to the rear panel IF OUTPUTS.

Power Divider (N5262-80003)

A four-way power divider provides each Port LO Output from the LO amplifier with approximately 7.2 dB attenuation for each LO Out. Two 50 ohm terminators are installed on the unused N5261A divider paths. If a system is configured with a unused port (a 1 port reflection system for example) the front panel LO Output ports are to be terminated with a 50 ohm load (1810-0118). This keeps the power divider balanced and prevents an “open” reflective signal from entering the power divider and mixing with the RF signal.

RF Switch (5087-7238)

A solid-state switch with internal 50 ohm termination is used for switching the RF Output path for Ports 1 and 2, or Ports 3 and 4. These switches are controlled by the Test Set Controller and Interface Boards.

Figure 52 N5261A Block Diagram

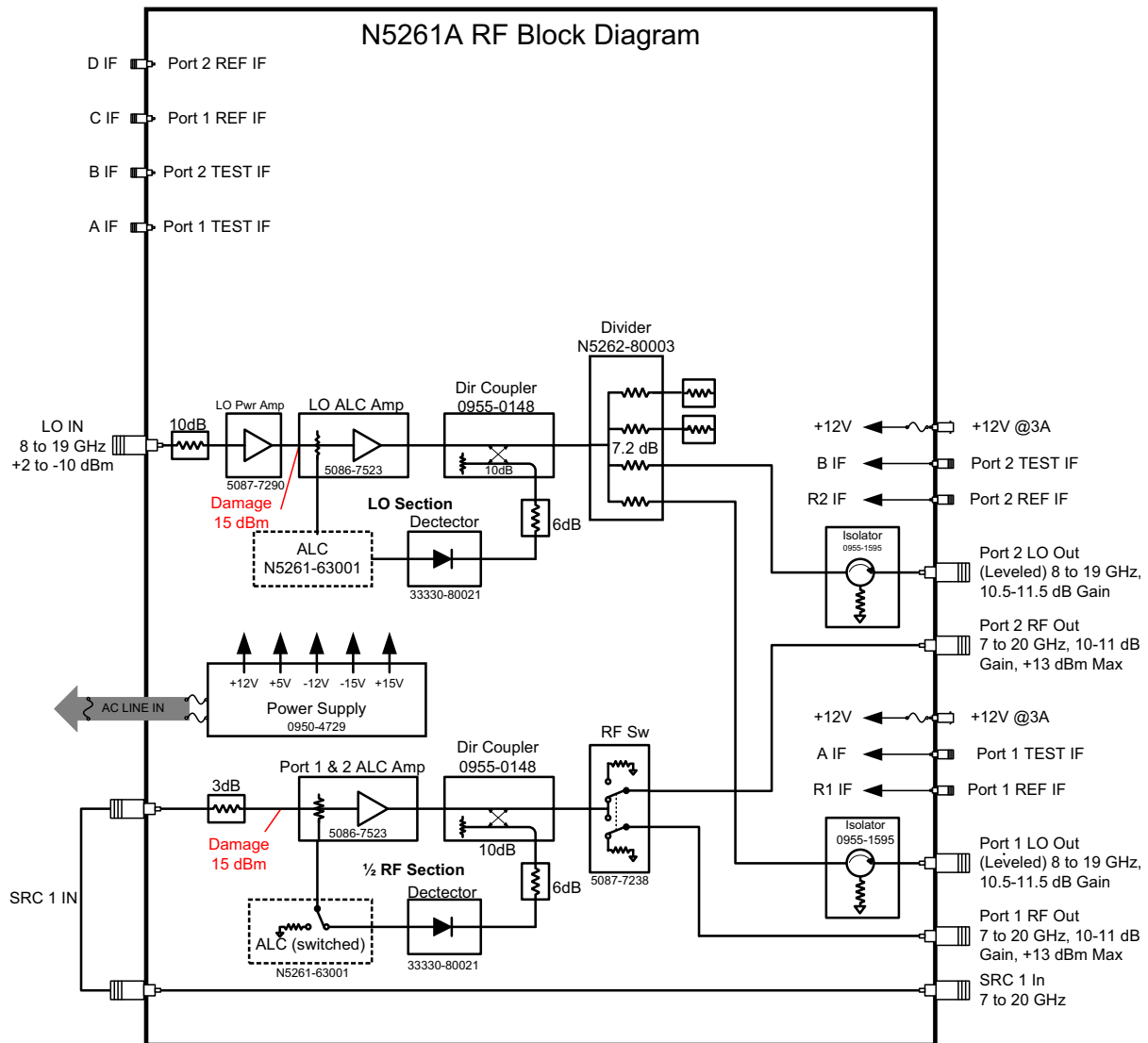

Figure 53 N5262A Block Diagram

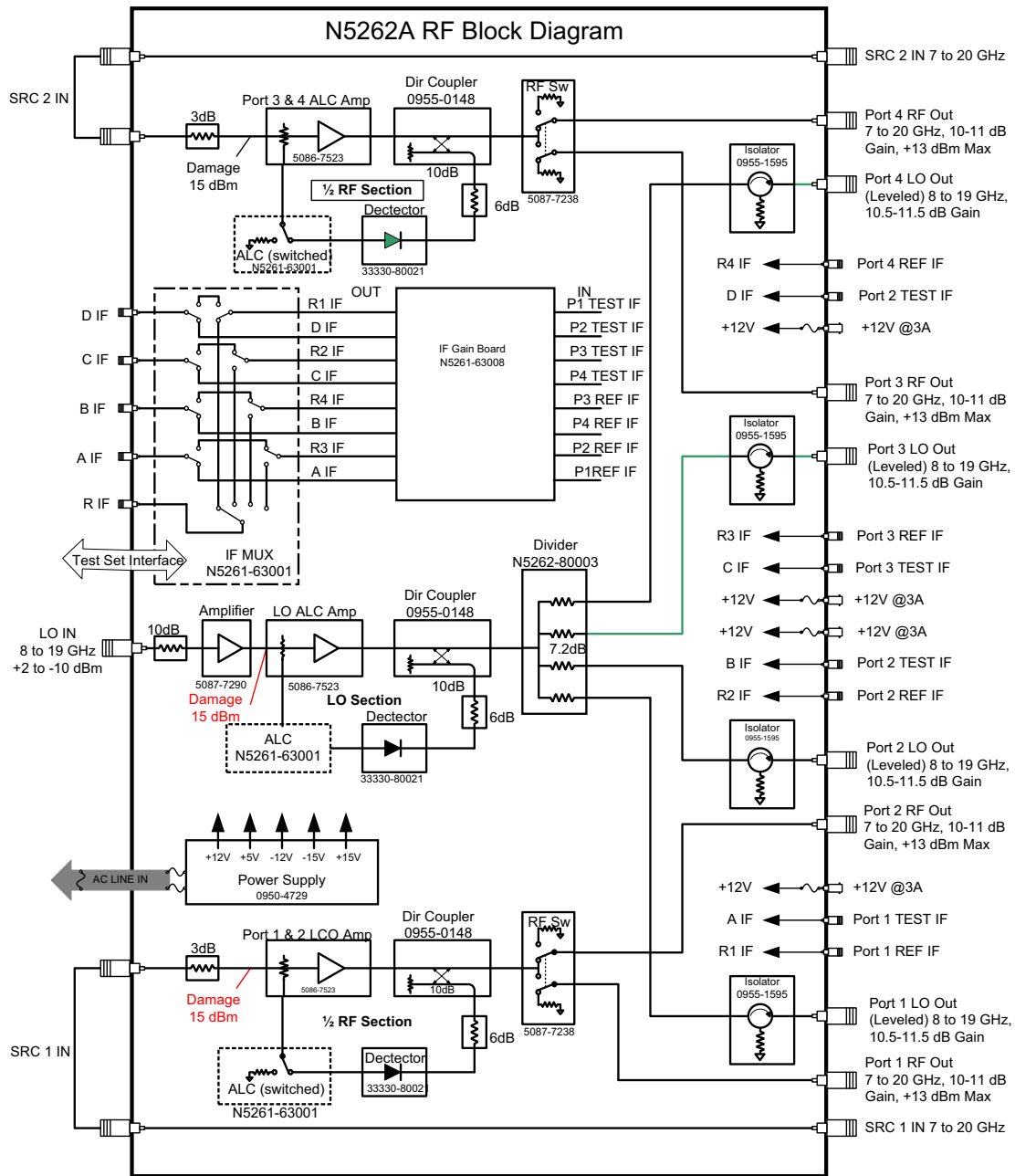

Figure 54 IF Routing 2-Port

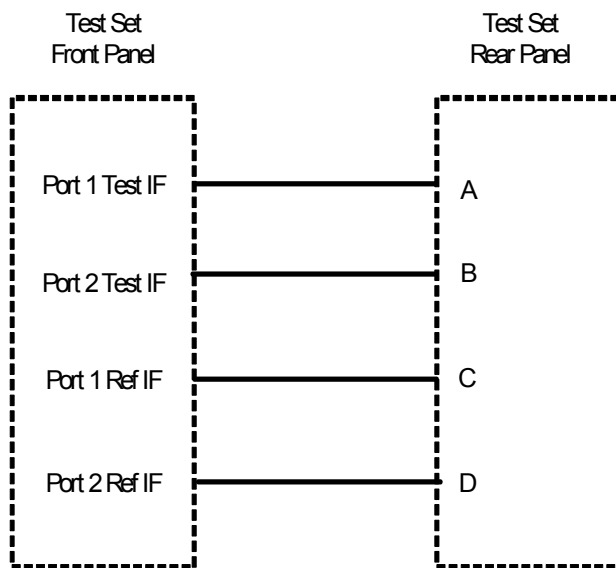
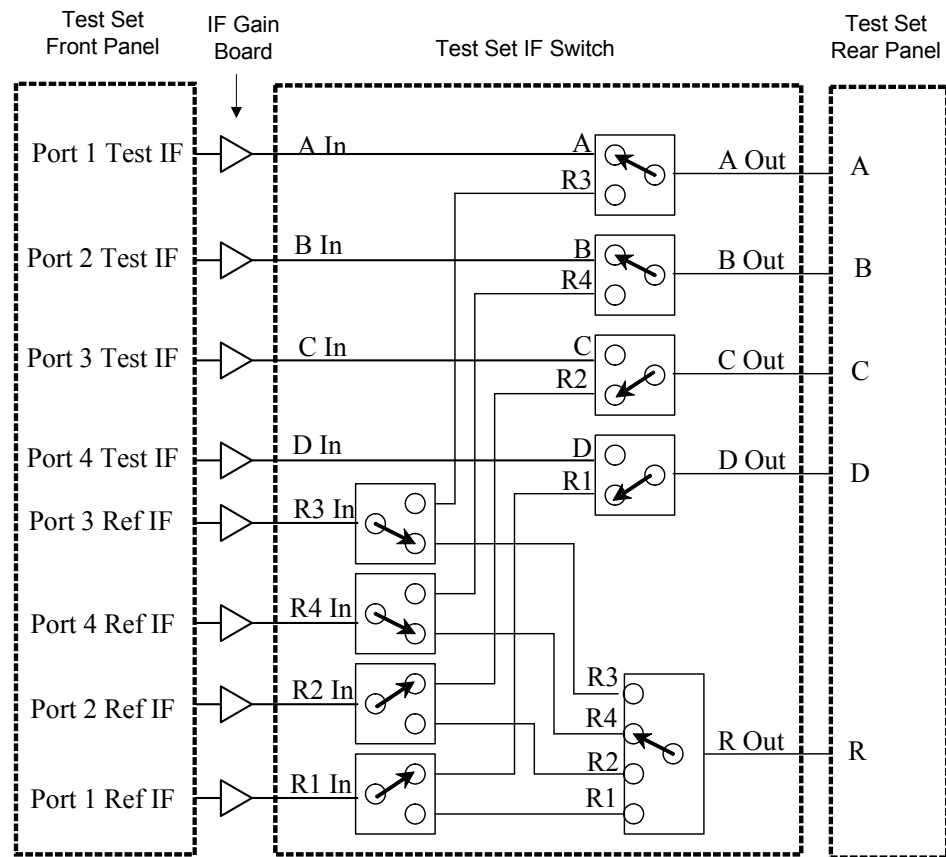

Figure 55 IF Routing 4-Port



Troubleshooting

If the N5251/62A is not operating properly, use the following procedures to isolate and repair the type of failure encountered. It is recommended that a qualified service technician perform the following procedures.

Refer to the Agilent PNA Series: Service & Support Home Page at: <http://na.tm.agilent.com/pna> for further information.

To request service, please contact your local service center. In the US, call 800-829-4444. For a listing of service centers worldwide, please visit us at www.agilent.com/find/service.

WARNING **No operator serviceable parts inside. Refer servicing to qualified personnel. To prevent electrical shock do not remove covers.**

Fan is not Operating

Suspect a power supply problem or failed fan, and perform the following troubleshooting.

WARNING **The opening of covers or removal of parts is likely to expose the user to dangerous voltages. Disconnect the instrument from all voltage sources while it is being opened.**

1. Verify the front panel power switch (3101-4058) is operational.
2. Verify that the AC line voltage is correct (100 to 240 V @ 50/60 Hz) and that the power cord is not damaged.
 - a. If the power cord is damaged, replace it.
 - b. If the AC line voltage is incorrect, use another receptacle.
3. Verify that the line module fuse (2110-0709) is not blown. There is a spare fuse in the line module. Refer to [Figure 6 on page 19](#). If the fuse is working, continue to [step 4](#).
4. Remove the top cover. Verify that the supply LED indicators on the test set control board (N5261-60006) are illuminated. If the LED's are illuminated, replace the fan (87050-60027). Refer to [Figure 60 on page 77](#).
5. If the LED's are *off*, verify the voltages (+24, +5, +3, -15, -12, +15, +12, +9, and +10 Volt) on the Test Set Controller board. If the voltages are not correct, verify that J10 - J14 cables are connected correctly on both the power supply and controller board. Refer to [Figure 60 on page 77](#).
6. If the J10 - J14 cables are connected properly, measure the voltages on the power supply screw terminals. See the power supply voltages in [Figure 56 on page 68](#) and [Table 16 on page 71](#).
7. If the power supply voltages are present, but the LEDs are off, replace the controller board. Note: When replacing the controller board, the model number and RF gain values will need to be entered into the new controller board.

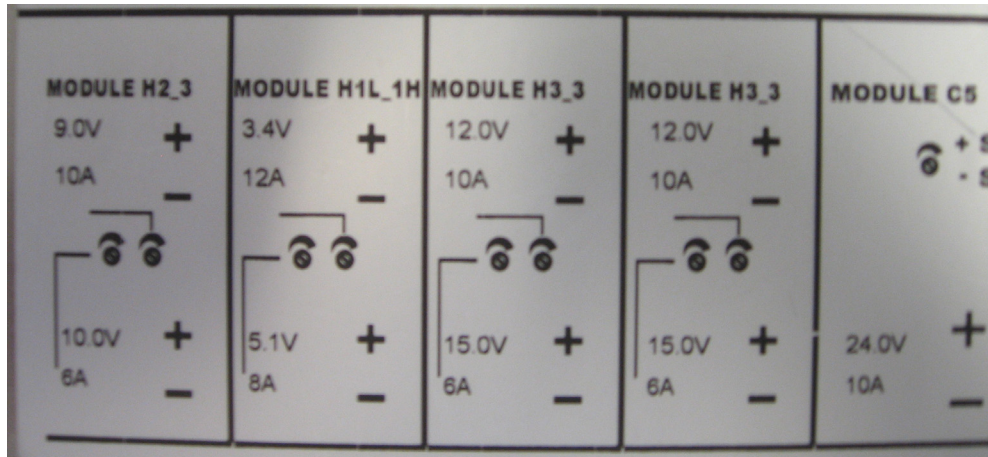
Figure 56 Power Supply Screw Terminal Voltage Levels

8. If power supply voltages are not present, verify and/or replace the two 8 amp fuses (2110-0342) in the line fuse assembly. Refer to [Figure 59 on page 76](#).
 - a. If the fuses are correct, replace power supply (0950-4729).

No DC Power for Millimeter-wave Modules

1. Suspect a DC power, or power supply problem.
2. Remove the top and bottom covers.
3. Inspect the DC Power Board (N5261-60002) connections.
4. Measure the +12 V (red wires) on the DC Power Board. If the +12 V is present, replace the DC power cable from the front panel (N5652-60001). If the +12 V is not present go to [step 5](#).
5. Verify that the supply LED indicators, on the test set Control Board (N5261-60006), are illuminated. If they are, replace the DC Power Board (N5261-60002). Refer to [Figure 60 on page 77](#). If the LED's are not illuminated, refer to ["Fan is not Operating" on page 67](#).

Over Current LEDs (amber) are On

1. Suspect a DC power, or cable short problem.
2. Remove all millimeter module connections from the front panel. If the over current LEDs are *off*, suspect the millimeter module or the DC Power Bias cable. If the LEDs are *on* continue with [step 3](#).
3. Verify that the +12 V on the front panel DC Power connectors is not shorted to ground. Refer to ["Non-System Operation Check" on page 38](#). If it is shorted to ground, replace the front panel DC Power cable (N5652-60001) or the DC Power Board (N5261-60002). If it is not shorted to ground continue to [step 4](#).
4. Exchange the LED Status Board (N5261-60005) with the DC Power LED Board and verify that the LEDs are illuminated. If the LEDs are still *on* replace the DC Power Board. If the LED's are *off* replace the DC Power LED Board (N5261-60005).

Front Panel LEDs R, S or DC Power (green) are not Illuminated

If the N5261/62A fan and power supplies are operating the following procedures can be used to verify the failure. Suspect the Test Set Controller Board (N5261-60006) or Front Panel LED Assembly (N5261-60005).

1. Verify the Test Set I/O cable (8120-6818) is installed correctly. See “Rear Panel Cabling” on page 29.
2. Using the I/O command values [Table 15](#) confirm the port status LEDs are illuminated.
3. Remove the top cover. Verify that the supply LED indicators, on the test set control board (N5261-60006), are illuminated.
4. If the LED’s are *off*, verify the voltages (+24, +5, +3, -15, -12, +15, +12, +9 and +10 Volt) on the Test Set Controller board. If the voltages are not correct, verify that J10 - J14 cables are connected correctly on both the power supply and controller board. Refer to “Fan is not Operating” on page 67.
5. Verify at least one of the controller board status LED is on. If not, replace the controller board (N5261-60006). See [Table 58 on page 75](#).
6. If the controller board status LEDs are on and the front panel ACTIVE LED is on, suspect the LED Board (N5261-60005) or the ribbon cable (N5261-60001). Replace if necessary.

Table 15 I/O Command Values for Receiver and Source LEDs

Address & Data ¹	Power On	Port 1	Port 2	Port 3	Port 4
64, 0	on	off	off	off	off
64, 17	on	on	off	off	off
64, 34	on	off	on	off	off
64, 68	on	off	off	on	off
64, 136	on	off	off	off	on

1. If data 0 is sent, the LEDs will turn off.

NOTE In millimeter mode the receivers are always active for all ports, therefore the receiver LED port indicators will always be illuminated. Depending on the ports selected, the source LEDs maybe on or off.

Test Ports are not Switching (RF OUT)

If the test ports are not switching, the following procedures can be used to verify the failure. The procedures assume power supplies, controller board and front panel LEDs are working. Suspect the switch interface board, ribbon cable connection or RF switch.

1. Inspect the ribbon cable connections from the RF switches to the Switch Interface board (N5261-60001). Ensure the RF jumpers (E8356-20072) are installed on SRC1 IN/OUT and SRC2 IN/OUT on the rear panel.
2. Send a test set I/O command to verify the path for each port. Refer to [Measure RF OUT](#) on [Page 40](#) and [Table 11 on page 39](#).
3. Substitute a known good switch, or connect a known good wire-harness cable to a suspect switch and retest. Replace if necessary.
4. Measure the switch drive voltage on the Interface board (J60 or J61, Pin 1) for a change in voltage (+13.8 V or -13.0 V), use I/O command in [Table 12 on page 41](#). Replace the interface assembly or confirm that the controller assembly is functioning with LED Port status check.

No LO Output

1. Refer to [Measure the LO OUT and SRC1 & SRC2 RF paths](#): on [Page 38](#). If one or more of the LO ports are working, suspect the power divider. If all of the ports are not working, measure the power supply on the LO preamp or ALC amp. Replace if necessary.

Table 16 Controller Board Connections (N5261-60006)

From: Controller Board	To: Connection
J8	Port Status LED (front panel)
J16	Active LED (front panel)
J10	Power Supply
J11	DC Power Board (J6)
J12	DC Power Board (J9)
J13	Power Supply
J14	Power Supply

Table 17 DC Power Board Connections (N5261-60002)

From: DC Power Board	To: Connection
J1 - J4	Front Panel DC cables (N5262-60001)
J5	Power Supply
J6	Controller Board
J7	n/a
J8	Power Supply
J9	Controller Board

Table 18 Interface Board Connections (N5261-60001)

From: Interface Board	To: Connections
J10	ALC Amp (Port 1 & 2)
J11	ALC Amp (Ports 3 & 4)
J12	LO Preamp (J1)
J13	n/a
J14	LO ALC Amp
J60	RF Switch (Ports 1 & 2)
J61	RF Switch (Ports 3 & 4)
J100	IF Gain P4-T Output (P31)
J101	Rear Panel (D, IF Output)
J150	IF Gain P3-T Output (P21)
J151	Rear Panel (C, IF Output)
J200	IF Gain P2-T Output (P41)
J201	Rear Panel (B, IF Output)
J250	IF Gain P1-T Output (P11)
J251	Rear Panel (A, IF Output)
J300	IF Gain P1-R Output (P51)
J301	IF Gain P2-R Output (P81)
J302	IF Gain P4-R Output (P71)
J303	IF Gain P3-R Output (P61)

Table 19 IF Gain Board N5261-60008)

From: IF Gain Board	To: Connection
P1	LO Power Amp Power Supply Cable (J2)
P10 (P1-T Input)	Front Panel Test IF (Port 1)
P11 (P1-T Output)	Interface Board J250
P20 (P3-T Input)	Front Panel Test IF (Port 3)
P21 (P3-T Output)	Interface Board J150
P30 (P4-T Input)	Front Panel Test IF (Port 4)
P31 (P4-T Output)	Interface Board J100
P40 (P2-T Input)	Front Panel Test IF (Port 2)
P41 (P2-T Output)	Interface Board J200
P50 (P1-R Input)	Front Panel REF IF (Port 1)
P51 (P1-R Output)	Interface Board J300
P60 (P3-R Input)	Front Panel REF IF (Port 3)
P61 (P3-R Output)	Interface Board J303
P70(P4-R-T Input)	Front Panel REF IF (Port 4)
P71 (P4-R Output)	Interface Board J302
P80 (P2-R Input)	Front Panel REF IF (Port 2)
P81 (P2-R (Output)	Interface Board J301

Figure 57 N5262A Top Front View

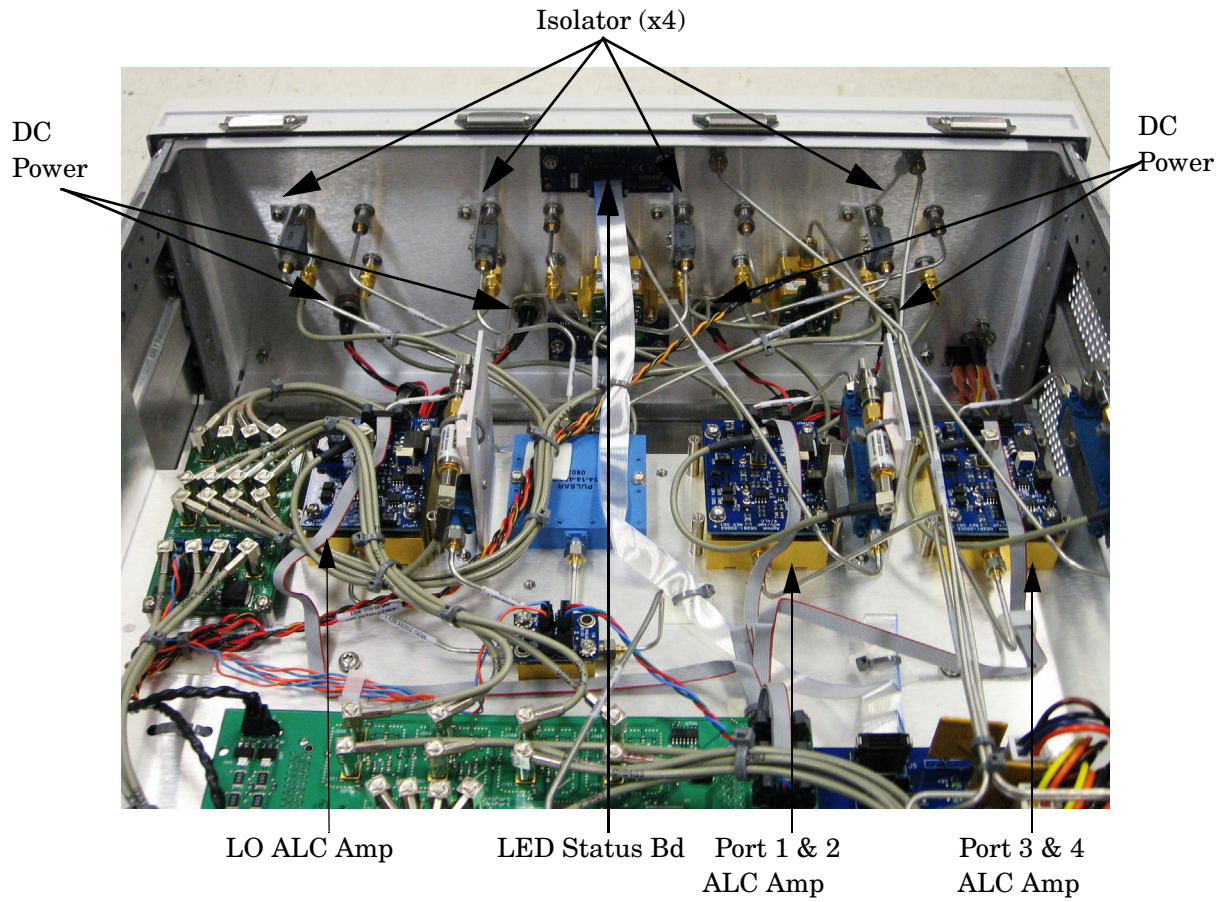

Figure 58 N5262A Top Vie5w

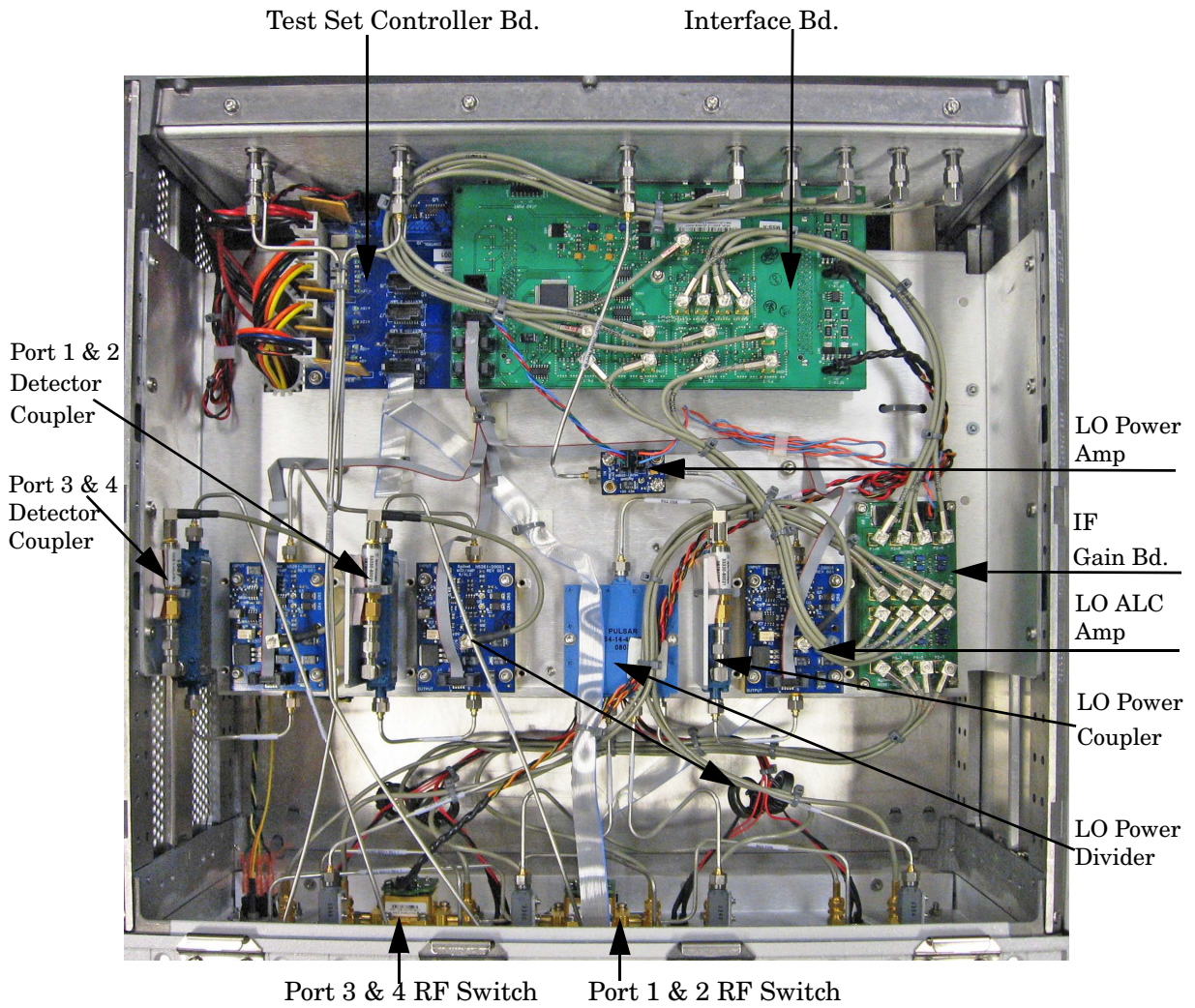

Figure 59 N5262A Bottom View

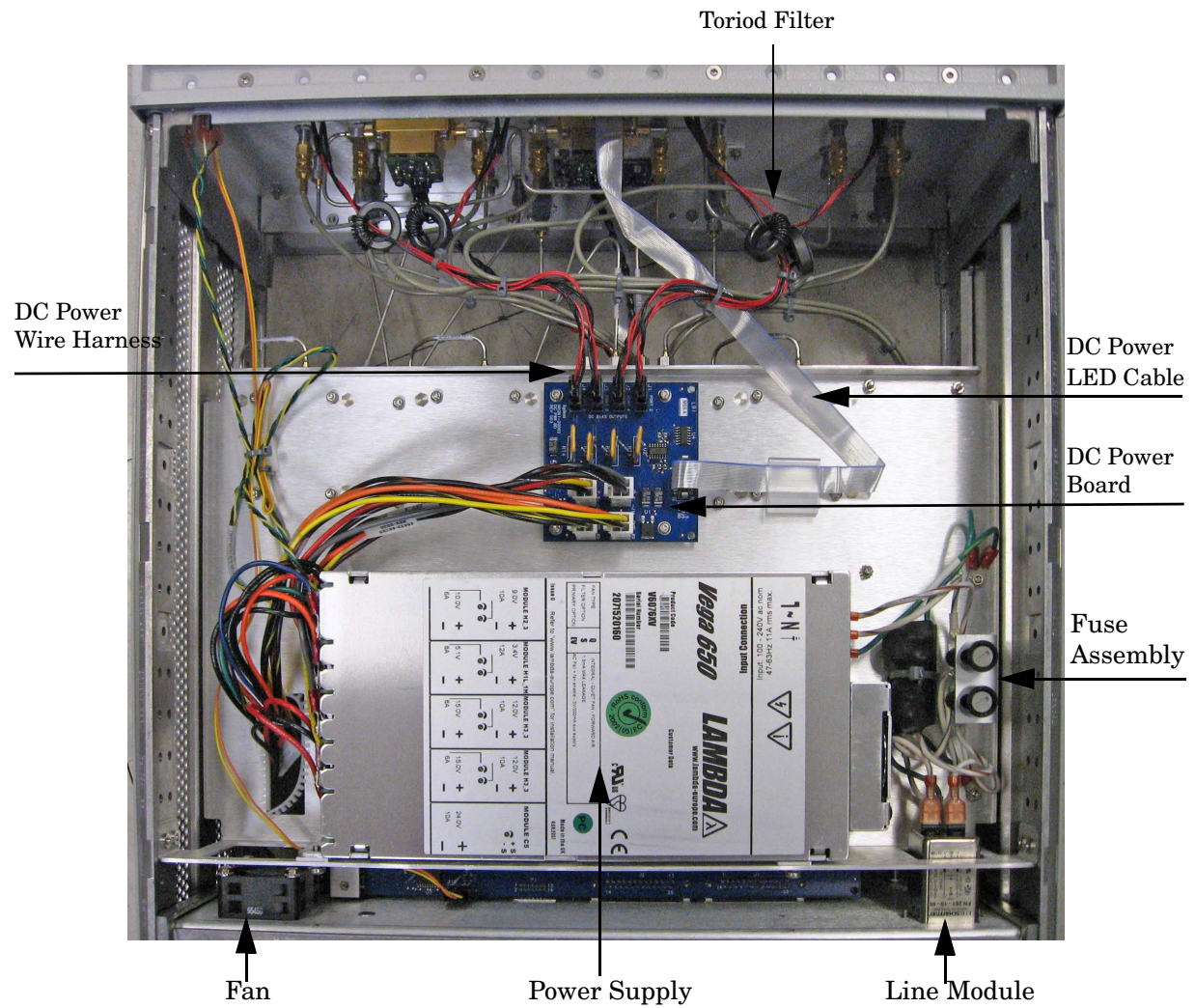

Figure 60 N5261A Top View

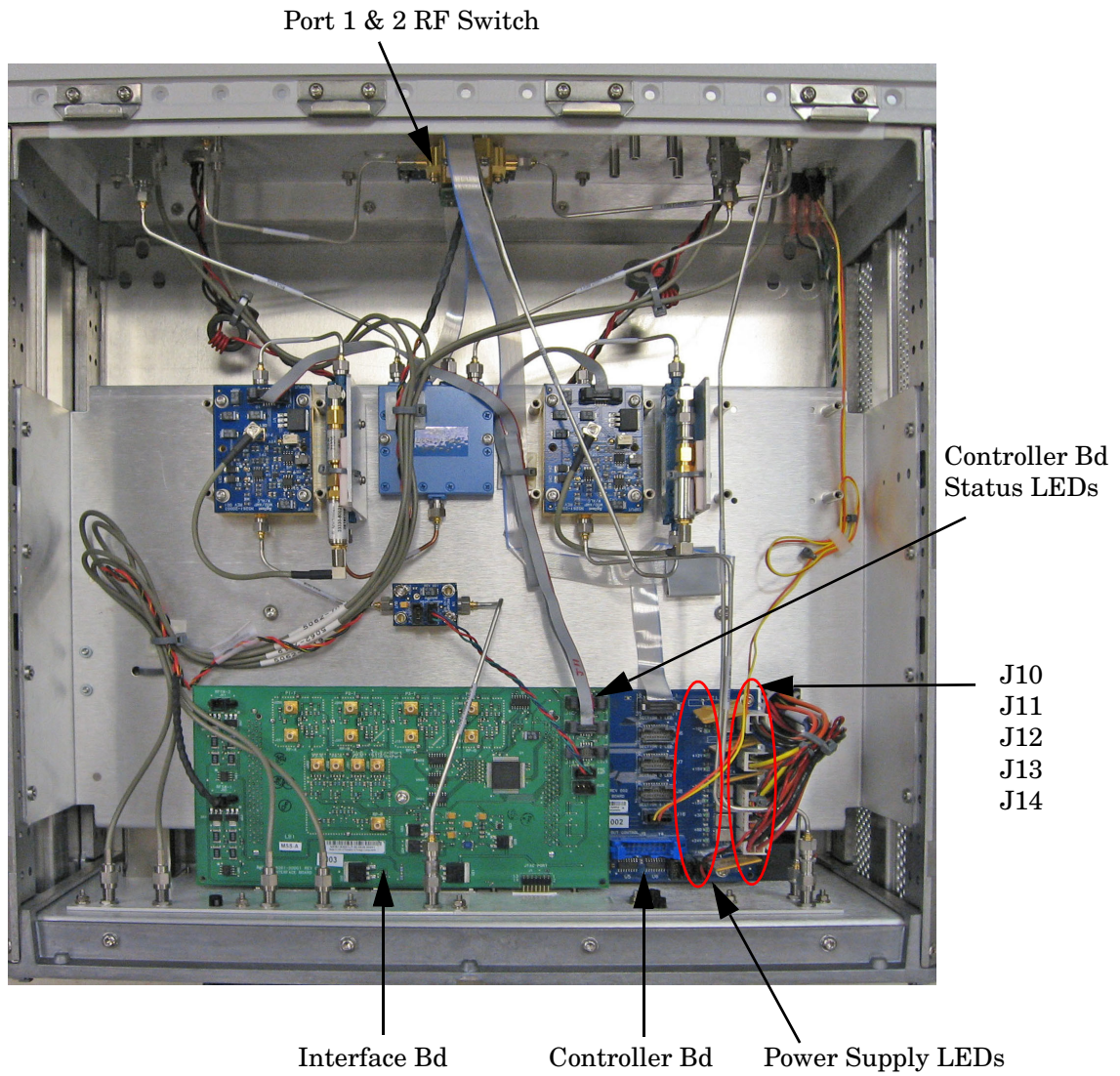
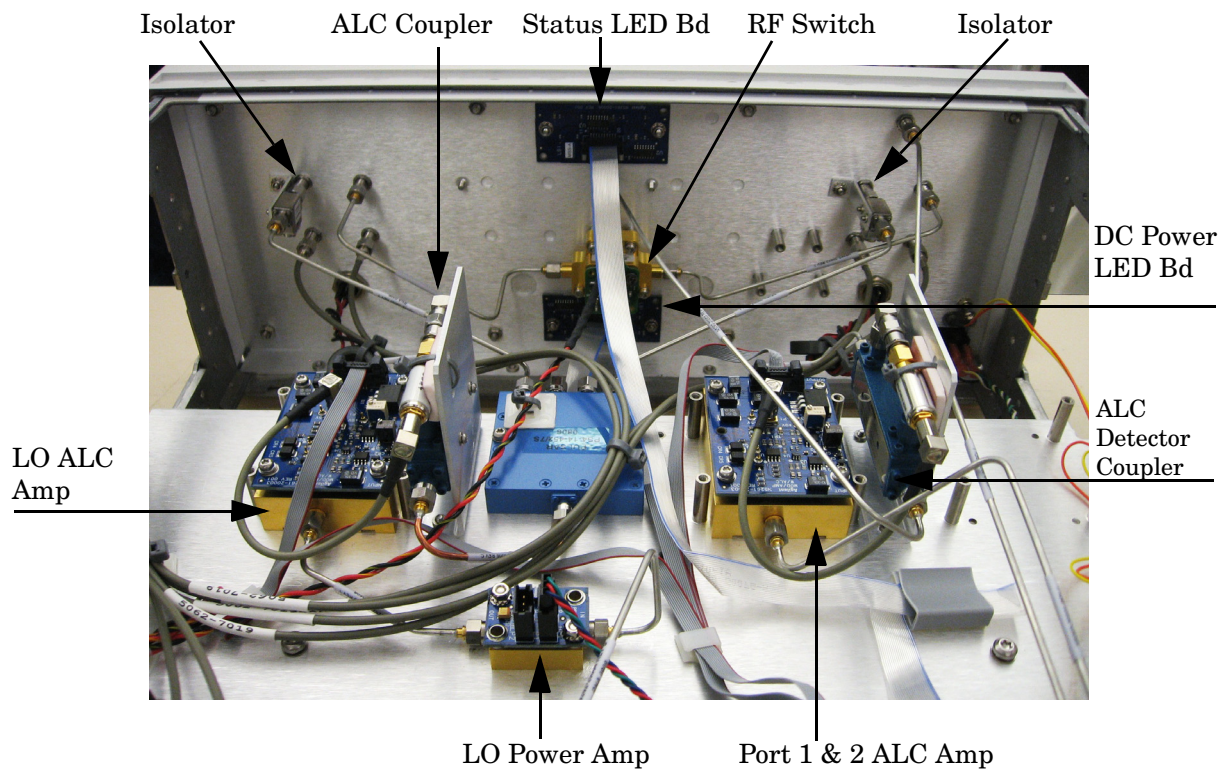

Figure 61 N5261A Top Front View



Safety and Regulatory Information

Introduction

Review this product and related documentation to familiarize yourself with safety markings and instructions before you operate the instrument. The documentation contains information and warnings that must be followed by the user to ensure safe operation and to maintain the product in a safe condition.

Before Applying Power

Verify that the premises electrical supply is within the range of the instrument. The instrument has an autoranging power supply.

WARNING To prevent electrical shock, disconnect the **Agilent Technologies N5261A and N5262A** from mains electrical supply before cleaning. Use a dry cloth or one slightly dampened with water to clean the external case parts. Do not attempt to clean internally.

Connector Care and Cleaning

If alcohol is used to clean the connectors, the power cord to the instrument must be removed. All cleaning should take place in a well ventilated area. Allow adequate time for the fumes to disperse and moist alcohol to evaporate prior to energizing the instrument.

WARNING Keep isopropyl alcohol away from heat, sparks, and flame. Store in a tightly closed container. It is extremely flammable. In case of fire, use alcohol foam, dry chemical, or carbon dioxide; water may be ineffective.

Declaration of Conformity

A copy of the Declaration of Conformity is available upon request, or a copy is available on the Agilent Technologies web site at <http://regulations.corporate.agilent.com/DoC/search.htm>

Statement of Compliance

This instrument has been designed and tested in accordance with CAN/CSA 22.2 No. 61010-1-04, UL Std No. 61010-1 (Second Edition), and IEC 61010-1 (Second Edition).

General Safety Considerations

Cautions applicable to this instrument

CAUTION The Mains wiring and connectors shall be compatible with the connector used in the premise electrical system. Failure, to ensure adequate earth grounding by not using the correct components may cause product damage, and serious injury.

CAUTION Always use the three prong AC power cord supplied with this product. Failure to ensure adequate earth grounding by not using this cord may cause product damage and the risk of electrical shock.

CAUTION This product is designed for use in Installation Category II and Pollution Degree 2.

CAUTION Verify that the premise electrical voltage supply is within the range specified on the instrument.

CAUTION Ventilation Requirements: When installing the instrument in a cabinet, the convection into and out of the instrument must not be restricted. The ambient temperature (outside the cabinet) must be less than the maximum operating temperature of the instrument by 4 °C for every 100 watts dissipated in the cabinet. If the total power dissipated in the cabinet is greater than 800 watts, forced convection must be used.

Servicing

Warnings applicable to this instrument.

-
- | | |
|----------------|--|
| WARNING | Danger of explosion if battery is incorrectly replaced. Replace only with the same or equivalent type recommended. Discard used batteries according to manufacturer's instructions. |
|----------------|--|
-
- | | |
|----------------|---|
| WARNING | For continued protection against fire hazard replace line fuse only with same type and rating. The use of other fuses or material is prohibited. |
|----------------|---|
-
- | | |
|----------------|--|
| WARNING | This is a Safety Class I product (provided with a protective earthing ground incorporated in the power cord). The mains plug shall be inserted only into a socket outlet provided with a protective earth contact. Any interruption of the protective conductor, inside or outside the product is likely to make the product dangerous. Intentional interruption is prohibited. |
|----------------|--|
-
- | | |
|----------------|---|
| WARNING | These servicing instructions are for use by qualified personnel only. To avoid electrical shock, do not perform any servicing unless you are qualified to do so. |
|----------------|---|
-
- | | |
|----------------|---|
| WARNING | The opening of covers or removal of parts is likely to expose the user to dangerous voltages. Disconnect the instrument from all voltage sources while it is being opened. |
|----------------|---|
-
- | | |
|----------------|---|
| WARNING | This product is designed for use in Installation Category II and Pollution Degree 2. |
|----------------|---|
-
- | | |
|----------------|--|
| WARNING | No operator serviceable parts inside. Refer servicing to qualified personnel. |
|----------------|--|
-
- | | |
|----------------|---|
| WARNING | If this product is not used as specified, the protection provided by the equipment could be impaired. This product must be used in a normal condition (in which all means for protection are intact) only. |
|----------------|---|
-

Regulatory Information

This section contains information that is required by various government regulatory agencies.

Instrument Markings



The instruction documentation symbol. The product is marked with this symbol when it is necessary for the user to refer to the instructions in the documentation.



This symbol indicates that the instrument requires alternating current (ac) input.



This symbol indicates separate collection for electrical and electronic equipment, mandated under EU law as of August 13, 2005. All electric and electronic equipment are required to be separated from normal waste for disposal (Reference WEEE Directive, 2002/96/EC).



This symbol indicates that the power line switch is ON.



This symbol indicates that the power line switch is in the STANDBY position.



This symbol indicates that the power line switch is in the OFF position.



This symbol is used to identify a terminal which is internally connected to the product frame or chassis.



The CE mark is a registered trademark of the European Community. (If accompanied by a year, it is when the design was proven.)



The CSA mark is a registered trademark of the CSA International. This instrument complies with Canada: CSA 22.2 No. 61010-1-04.

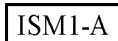

This is a symbol of an Industrial Scientific and Medical Group 1 Class A product.



This is a marking to indicate product compliance with the Canadian Interference-Causing Equipment Standard (ICES-001).



Direct Current.



The instrument has been designed to meet the requirements of IP 2 0 for ingress and operational environment.



This is a required mark signifying compliance with an EMC requirement. The C-Tick mark is a registered trademark of the Australian Spectrum Management Agency.



China RoHS regulations include requirements related to packaging, and require compliance to China standard GB18455-2001.



This symbol indicates compliance with the China RoHS regulations for paper/fiberboard packaging.

Battery Collection

Do not throw batteries away but collect as small chemical waste, or in accordance with your country's requirements. You may return the battery to Agilent Technologies for disposal. Refer to [“Contacting Agilent” on page 85](#) for assistance.

Compliance with German Noise Requirements

This is to declare that this instrument is in conformance with the German Regulation on Noise Declaration for Machines (Laermangabe nach der Maschinenlaermrrerordnung-3. GSGV Deutschland).

Acoustic Noise Emission/Geraeuschemission	
LpA<70 dB	Lpa<70 dB
Operator Position	am Arbeitsplatz
Normal Operation	normaler Betrieb
per ISO 7779	nach DIN 45635 t. 19

EMC Information

Complies with European EMC Directive 2004/108/EC

- IEC/EN 61326-1
- CISPR Pub 11 Group 1, class A
- AS/NZS CISPR 11
- This ISM device complies with Canadian ICES-001.
Cet appareil ISM est conforme a la norme NMB du Canada.

Electrostatic Discharge Protection

Protection against electrostatic discharge (ESD) is essential while removing assemblies from or connecting cables to the network analyzer. Static electricity can build up on your body and can easily damage sensitive internal circuit elements when discharged. Static discharges too small to be felt can cause permanent damage. To prevent damage to the instrument:

- *always* have a grounded, conductive table mat (9300-0797) in front of your test equipment.
- *always* wear a grounded wrist strap (9300-1367) with grounding cord (9300-0980), connected to a grounded conductive table mat, having a 1 M Ω resistor in series with it, when handling components and assemblies or when making connections.
- *always* wear a heel strap (9300-1126) when working in an area with a conductive floor. If you are uncertain about the conductivity of your floor, wear a heel strap.
- *always* ground yourself before you clean, inspect, or make a connection to a static-sensitive device or test port. You can, for example, grasp the grounded outer shell of the test port or cable connector briefly.
- *always* ground the center conductor of a test cable before making a connection to the analyzer test port or other static-sensitive device. This can be done as follows:
 1. Connect a short (from your calibration kit) to one end of the cable to short the center conductor to the outer conductor.
 2. While wearing a grounded wrist strap, grasp the outer shell of the cable connector.
 3. Connect the other end of the cable to the test port and remove the short from the cable.

Figure 62 ESD Protection Setup

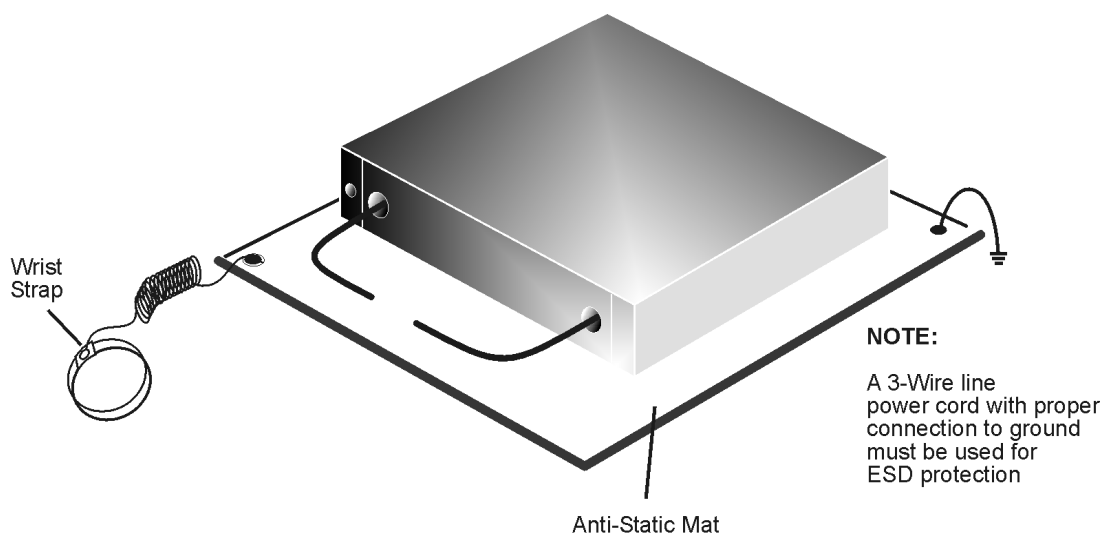

ku310b

Agilent Support, Services, and Assistance

Service and Support Options

The analyzer's standard warranty is a one-year return to Agilent Technologies service warranty.

NOTE There are many other repair and calibration options available from the Agilent Technologies support organization. These options cover a range of service agreements with varying response times. Contact Agilent for additional information on available service agreements for this product.

Contacting Agilent

Assistance with test and measurements needs and information or finding a local Agilent office are available on the Web at:

<http://www.agilent.com/find/assist>

You can also purchase accessories or documentation items on the Internet at:

<http://www.agilent.com/find>

If you do not have access to the Internet, contact your field engineer.

NOTE In any correspondence or telephone conversation, refer to the Agilent product by its model number and full serial number. With this information, the Agilent representative can determine the warranty status of your unit.

Shipping Your Analyzer to Agilent for Service or Repair

IMPORTANT Agilent Technologies reserves the right to reformat or replace the internal hard disk drive in your analyzer as part of its repair. This will erase all user information stored on the hard disk. It is imperative, therefore, that you make a backup copy of your critical test data located on the analyzer's hard disk before shipping it to Agilent for repair.

If you wish to send your instrument to Agilent Technologies for service or repair:

- Include a complete description of the service requested or of the failure and a description of any failed test and any error message.
- Ship the analyzer using the original or comparable antistatic packaging materials.
- Contact Agilent for instructions on where to ship your analyzer.

